

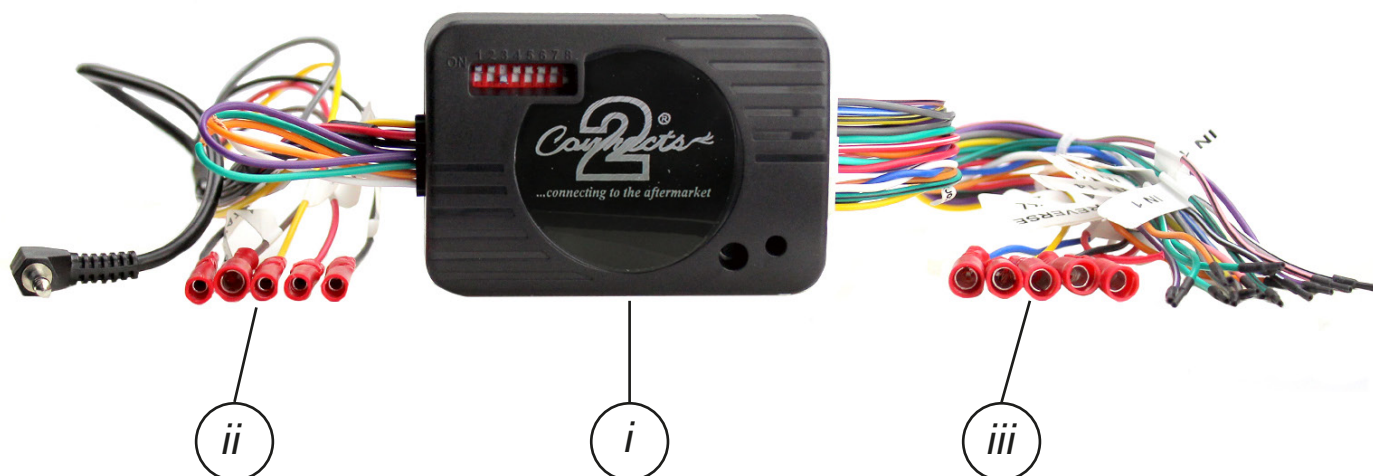

UNI-SWC.5

Universal Steering Wheel Control Interface



- i. UNI-SWC.5 Interface
- ii. Head Unit Connection (Patch) Lead
- iii. UNI-SWC.5 Wiring Harness

Designed and
Engineered
in the UK. 

APPLICATION

Note: Application data is subject to change at any time

- **900+ Vehicle Applications***

*Please note: application data is constantly being improved and amended as we expand the product's capabilities. Please visit www.connects2.com for the most up to date information and data regarding this interface.

FEATURES

- **Compatible with 900+ Vehicle Applications**
- **Works with Vehicles on Analogue, CAN-Bus, iBus, Class II and Matrix Platforms**
- **Retains Factory Steering Wheel Control Functions including Phone Buttons**
- **Allows Time/Date Change from Steering Wheel (*select models only*)**
- **Supports Voice Assistant (*select models only*)**
- **Analogue Learning System**
- **Button Remapping Feature**
- **Supports ACC, Illumination, Speed Pulse, Park Brake & Reverse Gear**
(*where vehicle data allows*)
- **Updateable via USB (*contact supplier for more information*)**

DISCLAIMER

The information provided in this document is subject to change without notice due to manufacturer changes and/or improvements to the product/s. This instruction manual is based on documented data and research. The manufacturer of this product cannot be held responsible for any changes made to the vehicle by the manufacturer or damages that may occur through the installation of this product in accordance with the steps outlined herein.

CONTENTS

I.	ABOUT	3
II.	PRIOR TO INSTALLATION	3
	a. CONNECTION DIAGRAM	3
	b. PREPARING THE PATCH LEAD	4
	c. SETTING THE DIPSWITCHES	4
	d. REMAPPING FUNCTIONS	4
III.	INSTALLATION	5
	a. STEP GUIDE	5
	b. PROGRAMMING THE INTERFACE	6
	c. ANALOGUE LEARNING HEAD UNITS	7
VI.	REMAPPING SOFTWARE	8
VII.	APPLICATION	9
	a. PRELIMINARY	9
	b. APPLICATION GUIDE	10
	c. ACCESSING SETTINGS MENUS	26
	d. DIAGRAM CHART	28

I. ABOUT

The UNI-SWC.5 interface is a universal steering wheel control solution designed to retain the steering wheel control functionality of a vehicle when the factory stereo is upgraded to an aftermarket model. The interface is compatible with over 900 vehicle applications across a variety of platforms and allows for the remapping of button functionality through a bespoke PC application.

II. PRIOR TO INSTALLATION

a. Connection Diagram

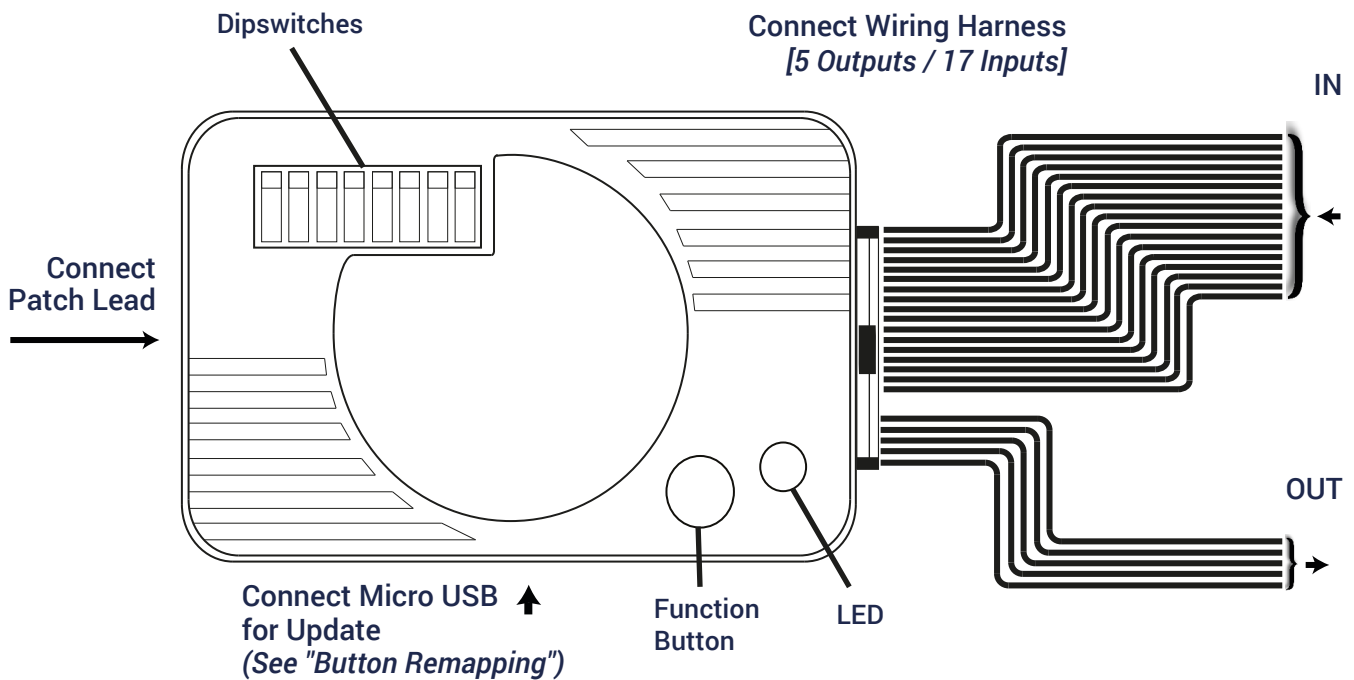

OUT	
Red/White	Acc. 12V
Orange	Illumination
Purple/White	Reverse Gear
Lt. Green	Park Brake
Lt. Pink	Speed Pulse

IN	
Green/Black	IN1
Blue	IN2
White	IN3
Orange/Black	IN4
Red	IN5
Green	IN6
White/Black	IN7
Grey	IN8
Black/White	IN9
Yellow/Black	IN10
Purple	IN11
Blue/White	IN12
Green/White	IN13
Grey/Black	IN14
Pink/Black	IN15
Black	Ground
Yellow	Batt 12V

b. Preparing the Patch Lead

The UNI-SWC.5 comes complete with a universal head unit connection/patch lead to provide compatibility with nearly every brand of aftermarket stereo on the market. Follow the instructions and table below to prepare the patch lead for installation based on the brand/type of stereo being installed into the vehicle.

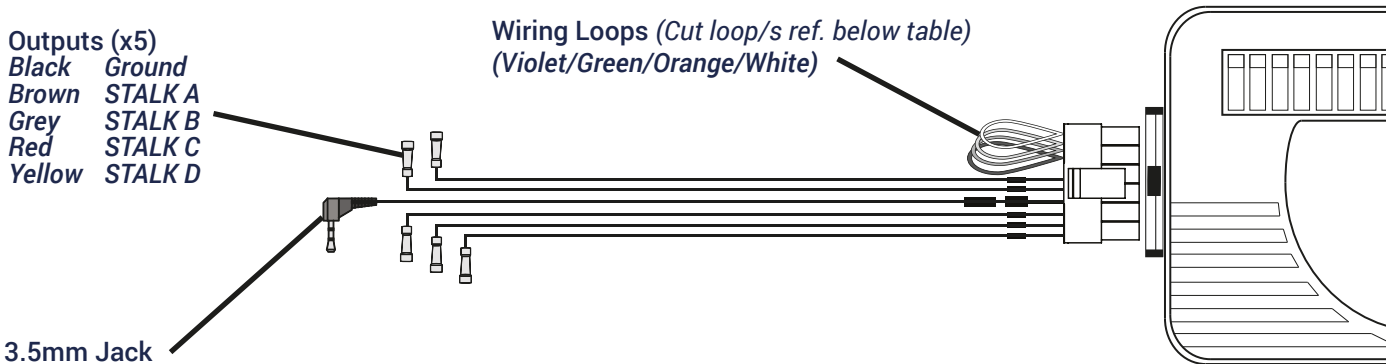

Stereo Brand	Loop Configuration	Stereo Connection
Alpine	Cut Green Loop	3.5mm Jack
Clarion	Cut Violet Loop	3.5mm Jack
JVC	Cut Green & Violet Loop	3.5mm Jack or Stalk A
Kenwood	Cut Orange & Green Loop	Stalk A
Panasonic	Cut Orange Loop	Stalk A
Pioneer	Cut White Loop	3.5mm Jack
Sony	No Cut Required	3.5mm Jack
Analogue Learning Units*	No Cut Required	Stalk C / Stalk D / Ground

*If an analogue learning stereo is being installed in the vehicle, please refer to Pg. 7. for more information

iii. Setting the Dipswitches

The UNI-SWC.5 interface has 8 individual dipswitches. Please set the dipswitches according to the information in the 'Application Guide' section (Pages 10 - 26) of this instruction manual.

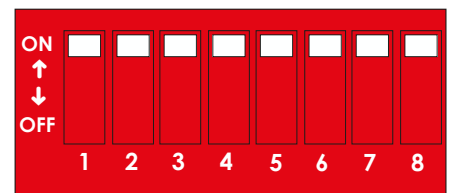

iv. Remapping Functions

The UNI-SWC.5 can be programmed to configure any vehicle function to any button, on either a long or short press. To begin button remapping, plug the interface into a computer via the Micro USB port and load up the SWC configuration software. If this step is skipped, a default configuration will be used.

Please see Pg. 8 for more information on how to remap button functionality.

III. INSTALLATION

a. Step Guide

Note: Prior to installation, ensure all required steps from the previous section have been completed, including preparing the patch lead, setting the interface dipswitches and remapping the button configuration (if desired).

Vehicle model not supported??

Note: Some vehicles on Analogue, Class II, and GM 11 platforms include steering wheel control functions that must be learned by the interface. Please refer to Pg. 6 for programming instructions prior to installation

- 1** Remove and disconnect the original head unit. Please see the vehicle owners' manual for more information.
 - 2** Connect the Patch Lead to the UNI-SWC.5 Interface
 - 3** Connect the patch lead to the aftermarket stereo, based on the brand/type of stereo being installed. (See 'Stereo Connection' column in table on Pg. 4).
- !!** **IMPORTANT: STEP 3 MUST BE COMPLETED BEFORE CONNECTING POWER TO THE INTERFACE. FAILURE TO DO SO MAY RESULT IN A LACK OF FUNCTIONALITY AND THE NEED TO REINSTALL THE PRODUCT.**
- 4** Find the desired vehicle application in the 'Application Guide' section of this manual. The row will contain information about how to correctly set up and wire the interface.
 - 5** Locate the relevant diagram number in the table. This diagram number refers the 'Diagram Chart' section at the back of this manual. Refer to the diagram referenced to find the locations of the wiring within the connector.
Note: All connector diagrams are shown from the terminal side, not the wiring side. Please take this into consideration when wiring this product.
 - 6** Connect the UNI-SWC.5 Wiring Harness to the UNI-SWC.5 Interface
 - 7** Install the interface into the vehicle, connecting Permanent 12V and Ground to suitable locations and then wiring it using the information found in the Application Guide and Diagram Chart sections of this instruction manual. IN5 must also be connected to a suitable switched 12V feed in the vehicle where indicated by the Application Guide table.
 - 8** Test interface for correct operation and reinstall the head unit.

Note: Car manufacturers can change wiring specifications without notice. Please ensure that the correct wires are located before commencing installation

b. Programming the Interface

When installing the UNI-SWC.5 into a currently unsupported Analogue, Class II or GM 11 vehicle, the interface must first 'learn' the buttons on the vehicle steering wheel.

Please follow the below steps to correctly configure the interface for use with the vehicle:

Set-Up

Please note that if the vehicle is also included in the 'Application Guide' section of this manual, the wiring in the table there must be connected in addition to the wiring below.

1. Connect the Ground wire (Black) from the UNI-SWC.5 Wiring Harness to the vehicle ground
2. Connect the IN5 wire from the UNI-SWC.5 Wiring Harness to the vehicle (if required)

Note: Some applications do not require IN5 to be connected. Please see 'Application Guide' section for information on whether to connect this wire, and if so, where to connect it in the vehicle.

3. Connect BATT 12V wire (Yellow) from the UNI-SWC.5 Wiring Harness to the 12V battery supply from the vehicle
4. Connect the relevant wiring to the vehicle depending on the vehicle platform (see 'Platform Guide' below)
5. Set Dipswitches depending on the vehicle platform (See 'Platform Guide' below)
6. The LED on the front of the interface will slowly glow green
7. Press and hold the **Function Button** for 5 seconds
8. The LED will flash red and then green

The interface is now ready to be programmed

Platform Guide

For Full Analogue Learning Vehicles

Set Dipswitches 1 - 8 to 'On'

Connect IN6 and IN7 from the UNI-SWC.5 Wiring Harness to the vehicle

1 1 1 1 1 1 1 1

For Class II Analogue Vehicles

Set Dipswitches 1,2,3,4,5,6,8 to 'On', 7 to 'Off'

Connect IN10 from the UNI-SWC.5 Wiring Harness to the vehicle

1 1 1 1 1 1 0 1

For GM 11 BIT (w/out RAP) Analogue Vehicles

Set Dipswitches 1,2,3,4,5,7 to 'On', 6 and 8 to 'Off'

Connect IN10 from the UNI-SWC.5 Wiring Harness to the vehicle

1 1 1 1 1 0 1 0

For GM 11 BIT (with RAP) Analogue Vehicles

Set Dipswitches 1,2,3,4,5,7,8 to 'On', 6 to 'Off'

Connect IN10 from the UNI-SWC.5 Wiring Harness to the vehicle

1 1 1 1 1 0 1 1

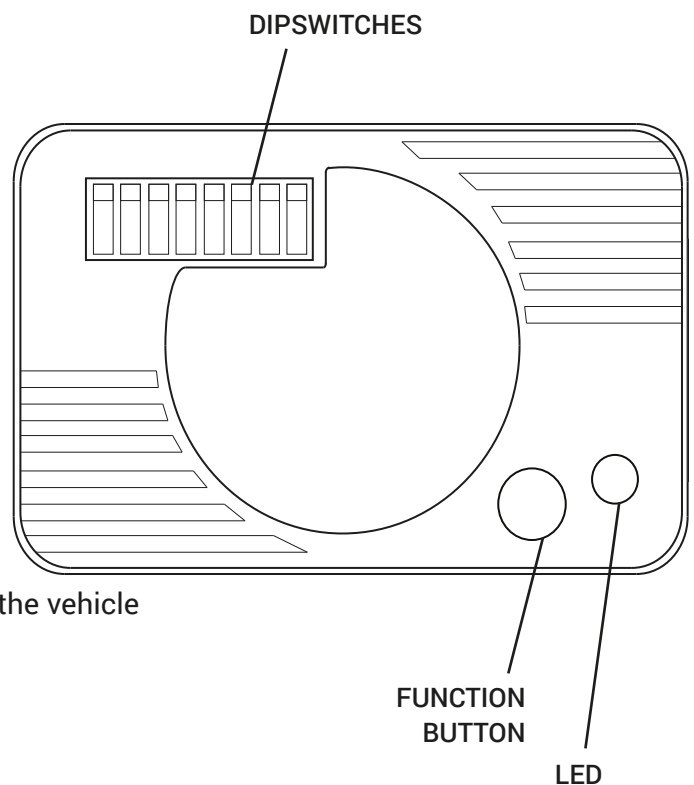

Programming

1. Start to program the buttons in the following order:

```
KEY_VOL_UP,  
KEY_VOL_DOWN,  
KEY_TRACK_UP,  
KEY_TRACK_DOWN,  
KEY_SOURCE,  
KEY_MUTE,  
KEY_DISK_UP,  
KEY_DISK_DOWN,  
KEY_PICKUP,  
KEY_HANGUP,  
KEY_PHONE, // Single Phone Button = Short Press - Pick Up / Long Press - Hang Up  
KEY_VOICE_RECOGNITION
```

2. Once a button value is seen, the **LED** will flash red, then move on to the next button by flashing green
3. If a key/button function is missing from the vehicle, press the **Function Button** to skip a key
4. Once complete, the LED will flash red twice and return to slowly glowing green
5. To restart the learning process from the beginning at any point, press and hold the **Function Button** for 5 seconds

c. Analogue Learning Head Units

Once the interface has been successfully connected to the vehicle, analogue learning head units will require the user to assign functions to the vehicle's buttons.

Analogue Learning Process

1. Once connected to the vehicle, the interface **LED** will slowly glow green.
2. Press the **Function Button** 10 times quickly*. The **LED** will now quickly flash red.
3. Program all buttons using the head unit's SWC learning menu and the vehicle's steering wheel control buttons.
4. When finished, press the **Function Button** 10 times quickly. The **LED** will return to a slow green glow.

**Note: By pressing the Function Button 10 times quickly, the interface is being put into a mode which allows it to stretch the outputs of the steering wheel control buttons. This allows the head unit to more effectively learn functions of buttons with a fast output time (ie. a scroll wheel). Although it is recommended that all buttons be programmed with this mode active to give the head unit a longer time to learn each output, Step 2 can be bypassed if desired, or activated only for learning specific buttons.*

VI. REMAPPING SOFTWARE

The UNI-SWC.5 can be programmed to configure any vehicle function to any button, on either a long or short press. To begin button remapping, plug the interface into a computer via the Micro USB port and load up the SWC configuration program (*visit www.connects2.com/home/news_downloads for more information*).

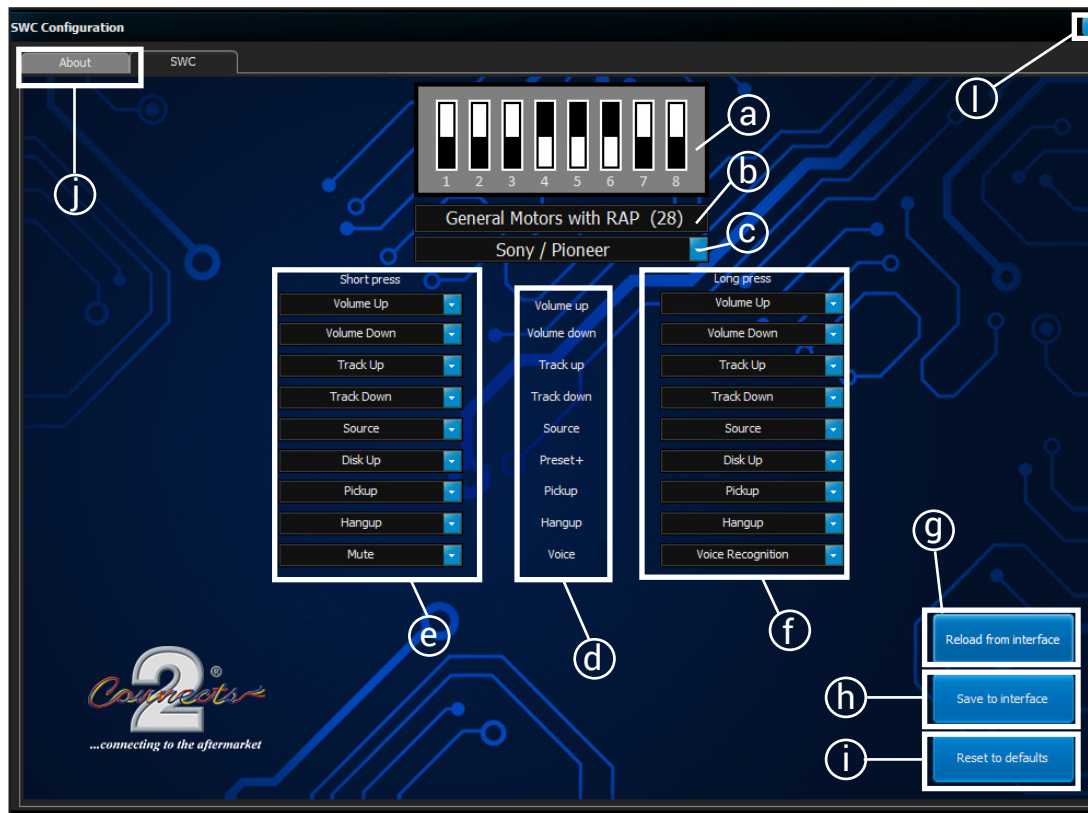

Set-Up

Upon connecting the interface, the software will correctly read its dipswitch settings (a) and display the vehicle's software platform (b).

Select the brand/type of aftermarket stereo from the drop-down list (c) and the central column will display all buttons available to program (d).

Remapping Buttons

Functions can be assigned as desired to each button by clicking on the drop-down arrows next to the menus in the left (e) and right (f) columns. The short press functionality of the button is dictated by the selection in the left column (e) and the long press functionality of the button is dictated by the selection in the right column (f).

For e.g.: In the above example, the vehicle's Voice button will function as Mute on a short press, and Voice Recognition on a long press.

Note: To reset the drop-down bars in the right and left columns to their default functions, press 'Reset to defaults' (i)

Saving Button Functions

To save the button configuration, press 'Save to interface' (h).

Reloading Default Configuration

To reload the configuration from the interface and overwrite any changes that have been made, press 'Reload from Interface' (g)

More Information and Exiting Software

To access more information about the software, press the 'About' tab (j).

To return to the configurator screen, press the 'SWC' tab.

Close the configurator window by pressing the 'X' icon (l)

VII. VEHICLE APPLICATION

a. Preliminary

Before locating your vehicle in the application tables, please familiarise yourself with the following items and their meanings:

Note: For Pontiac Solstice Vehicles

The Red/White Accessory OUT wire (ACC 12V) must be connected to the pin in car connector B, location 14 (Ref. Diagram 8).

Key	Column	Notes
1* - 7*	Menu Column	The vehicle menu can be accessed via the steering wheel controls and requires additional detail to explain functionality. Please consult the 'Accessing Settings Menu' pages of this manual (Pages 27-28).
S12V*	IN5	Connect to Switched 12V feed
**	Any Column	This vehicle has analogue steering wheel controls and must be programmed according to the specific instructions in this manual. Please consult the 'Programming the Interface' pages of this manual (Pages 6-7).
Tick/Cross	Any Column	The vehicle supports/does not support the function described.
TC	Any Column	'To Chassis'. Connect the input to a suitable point on the vehicle chassis
*PM	Ford Vehicles	The IN7 wire must be connected to the vehicle's phone module. Please see the vehicle owners manual for more information on how to locate the module.
iBus*	BMW Vehicles	A 4k7 resistor will need to be connected between the Batt 12V wire and the IN4 (iBus) wire
2PIN*	Saab Vehicles	The wire must be connected to the green wire in the 2 pin connector located under the steering wheel column (please note: the wire may need to be extended)



Man.	Model	Year From	Year To	Phone Button Support	Voice Assistant Support	Menu	Platform	Dipswitch Setting (0 - Off / 1 - On)								Diagram No.	IN6	IN7	Ana. GND	IN2	IN3	IN5	IN1	IN4	IN8	IN9	IN13	IN14	IN15	IN10
								1	2	3	4	5	6	7	8															
	4007	2007	2013	✓	×	×	Analogue	0	1	1	0	1	0	1	0	1	6	A9	N/A	TC	Together	A10	N/A	N/A	N/A	N/A	N/A	N/A	N/A	
	4007	2007	>	✓	×	×	Analogue	0	1	1	0	1	0	1	0	1	16	A9	N/A	TC	Together	A10	N/A	N/A	N/A	N/A	N/A	N/A	N/A	
	4008	2014	>	✓	×	×	Analogue	0	1	1	0	1	0	1	0	1	16	N/A	N/A	TC	Together	A10	N/A	N/A	N/A	N/A	N/A	N/A	N/A	
	4008	2014	>	✓	×	×	Analogue	0	1	1	0	1	0	1	0	1	16	N/A	N/A	TC	Together	A10	N/A	N/A	N/A	N/A	N/A	N/A	N/A	
	5008	2009	2013	×	×	1*	CAN	0	1	0	0	1	1	1	0	2	N/A	N/A	N/A	10	13	N/A	N/A	N/A	N/A	N/A	N/A	N/A	N/A	
	207 (Open Dash Only)	2006	2012	×	×	×	CAN	1	1	1	1	0	1	0	1	2	N/A	N/A	N/A	10	13	N/A	N/A	N/A	N/A	N/A	N/A	N/A	N/A	
	308 (Open Dash Only)	2009	>	×	×	×	CAN	1	1	1	1	0	1	0	1	2	N/A	N/A	N/A	10	13	N/A	N/A	N/A	N/A	N/A	N/A	N/A	N/A	
	308 (Open Dash Only)	2005	2008	×	×	×	CAN	1	1	1	1	0	1	0	1	2	N/A	N/A	N/A	10	13	N/A	N/A	N/A	N/A	N/A	N/A	N/A	N/A	
	407 (Open Dash Only)	2007	>	×	×	×	CAN	1	1	1	1	0	1	0	1	2	N/A	N/A	N/A	10	13	N/A	N/A	N/A	N/A	N/A	N/A	N/A	N/A	
	607 (Open Dash Only)	2004	2010	×	×	×	CAN	1	1	1	1	0	1	0	1	2	N/A	N/A	N/A	10	13	N/A	N/A	N/A	N/A	N/A	N/A	N/A	N/A	
	807 (Open Dash Only)	2005	2014	×	×	×	CAN	1	1	1	1	0	1	0	1	2	N/A	N/A	N/A	10	13	N/A	N/A	N/A	N/A	N/A	N/A	N/A	N/A	
	Bipper	2008	>	✓	×	×	CAN	0	1	1	1	1	1	0	1	1	1	N/A	N/A	N/A	5	6	N/A	N/A	N/A	N/A	N/A	N/A	N/A	
	Boxer	2006	2008	×	×	×	CAN/Analogue	0	1	1	1	0	1	1	0	1	1	20	33	27	5	6	N/A	N/A	N/A	N/A	N/A	N/A	N/A	
	Boxer	2008	2014	×	×	×	CAN/Analogue	0	1	1	1	0	1	1	0	1	1	20	33	27	5	6	N/A	N/A	N/A	N/A	N/A	N/A	N/A	
	Boxer	2014	>	✓	×	×	CAN	1	1	1	1	1	0	0	0	4	N/A	N/A	N/A	2	12	N/A	N/A	N/A	N/A	N/A	N/A	N/A	N/A	
	Boxer	2015	>	✓	×	×	CAN	1	1	1	1	1	1	0	0	4	N/A	N/A	N/A	2	12	N/A	N/A	N/A	N/A	N/A	N/A	N/A	N/A	
	Expert	2016	>	×	×	×	CAN	1	1	1	1	0	1	0	1	18	N/A	N/A	N/A	55	44	N/A	N/A	N/A	N/A	N/A	N/A	N/A	N/A	
	Expert	2016	>	×	×	×	CAN	1	1	1	1	0	1	0	1	2	N/A	N/A	N/A	10	13	N/A	N/A	N/A	N/A	N/A	N/A	N/A	N/A	
	Partner	2008	>	×	×	1*	CAN	0	1	0	0	1	1	1	0	2	N/A	N/A	N/A	10	13	N/A	N/A	N/A	N/A	N/A	N/A	N/A	N/A	
	RCZ	2010	>	×	×	1*	CAN	0	1	0	0	1	1	1	0	2	N/A	N/A	N/A	10	13	N/A	N/A	N/A	N/A	N/A	N/A	N/A	N/A	
	Azteck	2001	2005	✓	×	×	Class II	1	1	1	0	0	1	1	1	8	N/A	N/A	N/A	Together	N/A	N/A	N/A	N/A	N/A	N/A	N/A	N/A	N/A	
	G55	2007	2009	×	×	×	CAN (SW)	1	1	1	0	1	0	0	1	8	N/A	N/A	N/A	Together	N/A	N/A	N/A	N/A	N/A	N/A	N/A	N/A	N/A	
	Grand AM	2001	2005	✓	×	×	Class II	1	1	1	0	0	1	1	1	8	N/A	N/A	N/A	Together	N/A	N/A	N/A	N/A	N/A	N/A	N/A	N/A	N/A	
	G56	2005	2009	✓	×	×	CAN (SW)	1	1	1	0	0	1	0	1	8	N/A	N/A	N/A	Together	N/A	N/A	N/A	N/A	N/A	N/A	N/A	N/A	N/A	
	Montana	2001	2006	✓	×	×	Class II	1	1	1	0	0	1	1	1	8	N/A	N/A	N/A	Together	N/A	N/A	N/A	N/A	N/A	N/A	N/A	N/A	N/A	
	Solstice (See Pg. 9)	2008	>	×	×	×	GM 1.1 BIT RAP	1	1	1	1	1	0	1	1	8	N/A	N/A	N/A	Together	N/A	N/A	N/A	N/A	N/A	N/A	N/A	N/A	A11	
	Sunfire	2004	>	✓	×	×	Class II	1	1	1	0	0	1	1	1	8	N/A	N/A	N/A	Together	N/A	N/A	N/A	N/A	N/A	N/A	N/A	N/A	N/A	
	911	?	?	✓	×	×	Class II	0	0	1	1	1	1	1	1	1	N/A	N/A	N/A	30	17	N/A	N/A	N/A	N/A	N/A	N/A	N/A	N/A	
	Boxster	2004	2008	✓	×	×	CAN	0	0	1	1	1	1	1	1	1	N/A	N/A	N/A	30	17	N/A	N/A	N/A	N/A	N/A	N/A	N/A	N/A	
	Cayenne	2002	2007	✓	×	×	CAN	1	1	0	1	1	1	1	1	1	N/A	N/A	N/A	30	17	N/A	N/A	N/A	N/A	N/A	N/A	N/A	N/A	
	Cayenne	<	2010	✓	×	×	CAN	0	1	0	0	0	0	1	0	2	N/A	N/A	N/A	11	9	N/A	N/A	N/A	N/A	N/A	N/A	N/A	N/A	
	Cayman	2005	2009	✓	×	×	CAN	0	0	1	1	1	1	1	1	1	N/A	N/A	N/A	30	17	N/A	N/A	N/A	N/A	N/A	N/A	N/A	N/A	N/A
	GEN-2	2004	2012	×	×	×	Analogue	1	1	1	0	0	1	1	0	1	20	33	27	Together	8	N/A	N/A	N/A	N/A	N/A	N/A	N/A	N/A	N/A
	Promaster	2014	2014	✓	✓	×	CAN	1	1	1	1	1	1	0	0	4	N/A	N/A	N/A	2	12	N/A	N/A	N/A	N/A	N/A	N/A	N/A	N/A	
	Promaster City	2015	2015	✓	✓	×	CAN	1	1	1	1	1	1	0	0	4	N/A	N/A	N/A	2	12	N/A	N/A	N/A	N/A	N/A	N/A	N/A	N/A	N/A
	Clio	2000	2005	✓	×	×	Matrix	0	0	1	0	1	0	0	1	33	B4	B2	N/A	Together	A8	N/A	N/A	N/A	B5	B1	B3	N/A	N/A	
	Clio	2000	2005	✓	×	×	Matrix	0	0	1	0	1	0	0	1	33	B4	B2	N/A	Together	A8	N/A	N/A	N/A	B5	B1	B3	N/A	N/A	
	Clio	2009	2013	✓	×	6*	CAN	0	0	0	0	1	1	1	0	2	N/A	N/A	N/A	13	9	N/A	N/A	N/A	N/A	N/A	N/A	N/A	N/A	N/A
	Clio	2009	2013	✓	×	6*	CAN	0	0	0	0	1	1	1	0	1	N/A	N/A	N/A	17	30	N/A	N/A	N/A	N/A	N/A	N/A	N/A	N/A	N/A
	Clio	2005	2009	×	×	✓	CAN	0	0	0	0	0	1	1	0	1	N/A	N/A	N/A	B6	B2	N/A	N/A	N/A	N/A	N/A	N/A	N/A	N/A	N/A
	Fluence	2010	>	✓	×	6*	CAN	0	0	0	0	1	1	1	0	2	N/A	N/A	N/A	13	9	N/A	N/A	N/A	N/A	N/A	N/A	N/A	N/A	N/A
	Fluence	2010	>	✓	×	6*	CAN	0	0	0	0	1	1	1	0	1	N/A	N/A	N/A	17	30	N/A	N/A	N/A	N/A	N/A	N/A	N/A	N/A	N/A
	Kangoo	2000	2005	✓	×	×	Matrix	0	0	1	0	1	0	0	1	33	B4	B2	N/A	Together	A8	N/A	N/A	N/A	B5	B1	B3	N/A	N/A	
	Kangoo	2000	2005	✓	×	×	Matrix	0	0	1	0	1	0	0	1	33	B4	B2	N/A	Together	A8	N/A	N/A	N/A	B5	B1	B3	N/A	N/A	
	Laguna	2000	2005	✓	×	×	Matrix	0	0	1	0	1	0	0	1	33	B4	B2	N/A	Together	A8	N/A	N/A	N/A	B5	B1	B3	N/A	N/A	
	Laguna	2008	>	✓	×	6*	CAN	0	0	0	0	1	1	1	0	1	N/A	N/A	N/A	17	30	N/A	N/A	N/A	N/A	N/A	N/A	N/A	N/A	N/A
	Laguna	2005	2007	×	×	✓	CAN	0	0	0	0	0	1	1	0	1	N/A	N/A	N/A	B6	B2	N/A	N/A	N/A	N/A	N/A	N/A	N/A	N/A	N/A
	Master	2013	>	✓	×	×	Matrix	0	0	1	0	1	0	0	1	33	B4	B2	N/A	Together	A8	N/A	N/A	N/A	B5	B1	B3	N/A	N/A	
	Master	2015	>	✓	×	×	Matrix	0	0	1	0	1	0	0	1	33	B4	B2	N/A	Together	A8	N/A	N/A	N/A	B5	B1	B3	N/A	N/A	
	Megane	2000	2005	✓	×	×	Matrix	0	0	1	0	1	0	0	1	33	B4	B2	N/A	Together	A8	N/A	N/A	N/A	B5	B1	B3	N/A	N/A	
	Megane	2000	2005	✓	×	×	Matrix	0	0	1	0	1	0	0	1	33	B4	B2	N/A	Together	A8	N/A	N/A	N/A	B5	B1	B3	N/A	N/A	
	Megane	2008	2012	✓	×	6*	CAN	0	0	0	0	1	1	1	0	2	N/A	N/A	N/A	13	9	N/A	N/A	N/A	N/A	N/A	N/A	N/A	N/A	N/A
	Megane	2008	2012	✓	×	6*	CAN	0	0	0	0	1	1	1	0	1	N/A	N/A	N/A	17	30	N/A	N/A	N/A	N/A	N/A	N/A	N/A	N/A	N/A
	Megane	2005	2008	×	×	✓	CAN	0	0	0	0	0	1	1	0	1	N/A	N/A	N/A	B6	B2	N/A	N/A	N/A	N/A	N/A	N/A	N/A	N/A	N/A
	Modus	2004	2012	✓	×	×	Matrix	0	0	1	0	1	0	0	1	33	B4	B2	N/A	Together	A8	N/A	N/A	N/A	B5	B1	B3	N/A	N/A	

Man.	Model	Year From	Year To	Phone Button Support	Voice Assistant Support	Menu	Platform	Dipswitch Setting (0 - Off / 1 - On)								Diagram No.	IN6	IN7	Ana.GND	IN2	IN3	IN5	IN1	IN4	IN8	IN9	IN13	IN14	IN15	IN10
								1	2	3	4	5	6	7	8															
Volkswagen	Amarok	2010	>	✓	*	*	CAN (FT)	1	1	0	1	0	1	0	0	2	N/A	N/A	N/A	9	10	N/A	N/A	N/A	N/A	N/A	N/A	N/A		
	Amarok	2010	>	✓	*	*	CAN (HS)	1	1	0	1	0	1	0	0	2	N/A	N/A	N/A	9	10	N/A	N/A	N/A	N/A	N/A	N/A	N/A		
	Beetle	2015	>	✓	*	*	CAN (FT)	1	1	0	1	0	1	0	5	N/A	N/A	N/A	22	28	N/A	N/A	N/A	N/A	N/A	N/A	N/A			
	Caddy	2015	>	✓	*	*	CAN (FT)	1	1	0	1	0	1	0	5	N/A	N/A	N/A	22	28	N/A	N/A	N/A	N/A	N/A	N/A	N/A			
	CC	2009	2013	✓	*	*	CAN (FT)	1	1	0	1	0	1	0	2	N/A	N/A	N/A	9	10	N/A	N/A	N/A	N/A	N/A	N/A	N/A			
	Crafter	2006	>	✓	*	*	CAN	1	1	0	1	1	1	0	3	N/A	N/A	N/A	3	8	N/A	N/A	N/A	N/A	N/A	N/A	N/A			
	Crafter	2006	>	✓	*	*	CAN	1	0	1	1	1	1	0	3	N/A	N/A	N/A	3	8	N/A	N/A	N/A	N/A	N/A	N/A	N/A			
	EOS	2006	2015	✓	*	*	CAN (FT)	1	1	0	1	1	0	0	2	N/A	N/A	N/A	9	10	N/A	N/A	N/A	N/A	N/A	N/A	N/A			
	Fusca	2005	2011	✓	*	*	CAN (FT)	1	1	0	1	0	1	0	2	N/A	N/A	N/A	9	10	N/A	N/A	N/A	N/A	N/A	N/A	N/A			
	Fusca	2005	>	✓	*	*	CAN (HS)	1	1	0	1	0	1	0	2	N/A	N/A	N/A	9	10	N/A	N/A	N/A	N/A	N/A	N/A	N/A			
	Gol	2012	>	✓	*	*	CAN (HS)	0	0	1	0	0	1	0	2	N/A	N/A	N/A	9	10	N/A	N/A	N/A	N/A	N/A	N/A	N/A			
	Gol	2012	>	✓	*	*	CAN (HS)	0	0	1	0	0	1	0	2	N/A	N/A	N/A	9	10	N/A	N/A	N/A	N/A	N/A	N/A	N/A			
	Gol	2005	2012	✓	*	*	IR	0	0	0	0	1	0	1	1	1	N/A	N/A	N/A	Together	2	N/A	N/A	N/A	N/A	N/A	N/A			
	Golf 6	2003	2013	✓	*	*	CAN (FT)	1	1	0	0	0	1	1	0	2	N/A	N/A	N/A	9	10	N/A	N/A	N/A	N/A	N/A	N/A			
	Jetta	2005	2015	✓	*	*	CAN (FT)	1	1	0	1	1	0	1	0	2	N/A	N/A	N/A	9	10	N/A	N/A	N/A	N/A	N/A	N/A			
	Jetta	2005	2015	✓	*	*	CAN (HS)	1	1	0	1	0	1	0	2	N/A	N/A	N/A	9	10	N/A	N/A	N/A	N/A	N/A	N/A	N/A			
	Jetta	1999	2015	✓	*	*	LIN	0	0	0	0	1	0	1	1	1	N/A	N/A	N/A	Together	2	N/A	N/A	N/A	N/A	N/A	N/A			
	Jetta	2015	>	✓	*	*	CAN (FT)	1	1	0	1	0	1	0	5	N/A	N/A	N/A	9	10	N/A	N/A	N/A	N/A	N/A	N/A	N/A			
	Magotan	2005	2011	✓	*	*	CAN (FT)	1	1	0	1	0	1	0	2	N/A	N/A	N/A	9	10	N/A	N/A	N/A	N/A	N/A	N/A	N/A			
	Magotan	2005	>	✓	*	*	CAN (HS)	1	1	0	1	0	1	0	2	N/A	N/A	N/A	9	10	N/A	N/A	N/A	N/A	N/A	N/A	N/A			
	Multivan	2003	2009	✓	*	*	CAN (FT)	1	1	0	0	0	1	1	0	2	N/A	N/A	N/A	9	10	N/A	N/A	N/A	N/A	N/A	N/A			
	Passat	2005	2015	✓	*	*	CAN (FT)	1	1	0	1	0	1	0	2	N/A	N/A	N/A	9	10	N/A	N/A	N/A	N/A	N/A	N/A	N/A			
	Passat	2005	2015	✓	*	*	CAN (HS)	1	1	0	1	0	1	0	2	N/A	N/A	N/A	9	10	N/A	N/A	N/A	N/A	N/A	N/A	N/A			
	Passat	2005	2015	✓	*	*	CAN (FT)	1	1	0	1	0	1	0	2	N/A	N/A	N/A	9	10	N/A	N/A	N/A	N/A	N/A	N/A	N/A			
	Polo	2005	2014	✓	*	*	CAN (FT)	1	1	0	1	0	1	0	2	N/A	N/A	N/A	9	10	N/A	N/A	N/A	N/A	N/A	N/A	N/A			
	Polo	2005	2014	✓	*	*	CAN (HS)	1	1	0	1	0	1	0	2	N/A	N/A	N/A	9	10	N/A	N/A	N/A	N/A	N/A	N/A	N/A			
	Rabbit	2007	2008	✓	*	*	R32	1	1	0	1	0	1	0	2	N/A	N/A	N/A	9	10	N/A	N/A	N/A	N/A	N/A	N/A	N/A			
	Rabbit	2006	2008	✓	*	*	CAN (FT)	1	1	0	1	0	1	0	2	N/A	N/A	N/A	9	10	N/A	N/A	N/A	N/A	N/A	N/A	N/A			
	Sagitar	2005	2011	✓	*	*	CAN (FT)	1	1	0	1	0	1	0	2	N/A	N/A	N/A	9	10	N/A	N/A	N/A	N/A	N/A	N/A	N/A			
	Sagitar	2005	>	✓	*	*	CAN (HS)	1	1	0	1	0	1	0	2	N/A	N/A	N/A	9	10	N/A	N/A	N/A	N/A	N/A	N/A	N/A			
	Sirocco	2008	2015	✓	*	*	CAN (FT)	1	1	0	1	0	1	0	2	N/A	N/A	N/A	9	10	N/A	N/A	N/A	N/A	N/A	N/A	N/A			
	Sirocco	2008	2015	✓	*	*	CAN (HS)	1	1	0	1	0	1	0	2	N/A	N/A	N/A	9	10	N/A	N/A	N/A	N/A	N/A	N/A	N/A			
	Sirocco	2008	2015	✓	*	*	CAN (FT)	1	1	0	1	0	1	0	5	N/A	N/A	N/A	22	28	N/A	N/A	N/A	N/A	N/A	N/A	N/A			
	Sharan	2015	>	✓	*	*	CAN (FT)	1	1	0	1	0	1	0	5	N/A	N/A	N/A	22	28	N/A	N/A	N/A	N/A	N/A	N/A	N/A			
	Suran	2009	>	✓	*	*	CAN (FT)	1	1	0	1	0	1	0	2	N/A	N/A	N/A	9	10	N/A	N/A	N/A	N/A	N/A	N/A	N/A			
	Suran	2009	>	✓	*	*	CAN (HS)	1	1	0	1	0	1	0	2	N/A	N/A	N/A	9	10	N/A	N/A	N/A	N/A	N/A	N/A	N/A			
	T-6	2015	>	✓	*	*	CAN (FT)	1	1	0	1	0	1	0	5	N/A	N/A	N/A	22	28	N/A	N/A	N/A	N/A	N/A	N/A	N/A			
	Tiguan	2007	2015	✓	*	*	CAN (FT)	1	1	0	1	0	1	0	2	N/A	N/A	N/A	9	10	N/A	N/A	N/A	N/A	N/A	N/A	N/A			
	Tiguan	2008	2011	✓	*	*	CAN (FT)	1	1	0	1	0	1	0	2	N/A	N/A	N/A	9	10	N/A	N/A	N/A	N/A	N/A	N/A	N/A			
	Tiguan	2007	2015	✓	*	*	CAN (HS)	1	1	0	1	0	1	0	2	N/A	N/A	N/A	9	10	N/A	N/A	N/A	N/A	N/A	N/A	N/A			
	Tiguan	2015	>	✓	*	*	CAN (FT)	1	1	0	1	0	1	0	5	N/A	N/A	N/A	22	28	N/A	N/A	N/A	N/A	N/A	N/A	N/A			
	Touareg	2004	2010	✓	*	*	CAN (FT)	1	1	0	1	1	0	1	0	2	N/A	N/A	N/A	9	10	N/A	N/A	N/A	N/A	N/A	N/A			
Touareg	2003	2010	✓	*	*	CAN (FT)	1	1	0	0	1	1	0	2	N/A	N/A	N/A	9	10	N/A	N/A	N/A	N/A	N/A	N/A	N/A				
Touareg	2003	2015	✓	*	*	CAN (FT)	1	1	0	1	0	1	0	2	N/A	N/A	N/A	9	10	N/A	N/A	N/A	N/A	N/A	N/A	N/A				
Touran	2003	2015	✓	*	*	CAN (FT)	1	1	0	1	0	1	0	2	N/A	N/A	N/A	9	10	N/A	N/A	N/A	N/A	N/A	N/A	N/A				
Touran	2003	2015	✓	*	*	CAN (FT)	1	1	0	1	0	1	0	2	N/A	N/A	N/A	9	10	N/A	N/A	N/A	N/A	N/A	N/A	N/A				
Transporter	2003	2015	✓	*	*	CAN (FT)	1	1	0	1	0	1	0	2	N/A	N/A	N/A	9	10	N/A	N/A	N/A	N/A	N/A	N/A	N/A				
Transporter	2003	2015	✓	*	*	CAN (HS)	1	1	0	1	0	1	0	2	N/A	N/A	N/A	9	10	N/A	N/A	N/A	N/A	N/A	N/A	N/A				
Vento	2005	2011	✓	*	*	CAN (FT)	1	1	0	1	0	1	0	2	N/A	N/A	N/A	9	10	N/A	N/A	N/A	N/A	N/A	N/A	N/A				
Vento	2005	>	✓	*	*	CAN (HS)	1	1	0	1	0	1	0	2	N/A	N/A	N/A	9	10	N/A	N/A	N/A	N/A	N/A	N/A	N/A				

Config. 1 (1*)

To Enter Menu Mode

- Press and hold 'Mute' button for 2 seconds (Citroen vehicles) **or** press 'Track +' and 'Track -' buttons in unison (Peugeot vehicles)

To Navigate Through Settings

- Use 'Track +' and 'Track -' to navigate through settings and select a menu with 'Volume +' (Citroen/Peugeot vehicles).
- If the above step doesn't work, hold the 'Source' button (Peugeot vehicles) or 'Mute' button (Citroen vehicles) for 3 seconds. After 3 seconds, the display will return to radio mode.
- Now the scroll wheel can be used to adjust the selected menu item

NB: Once power has been removed from the interface, it will default back to its original settings

Config. 2 (2*)

To Adjust Clock

- Press & hold 'SET' button for 2 seconds
- Press 'Up' to change the hour
- Press 'Down' to change the minute
- Press and hold 'SET' button to exit or wait for 10 seconds

To Navigate Trip Computer

- Press the 'Right Arrow' button repeatedly until the clock in the vehicle display is highlighted
- Use the 'Up' and 'Down' buttons to navigate the trip computer

To Reset Trip Computer

- Navigate to the trip computer setting you wish to reset
- Press and hold 'SET' until the reading clears. The display should now show: ' _ _ _ '

Config. 3 (3*)

To Adjust Fader

- Press and hold 'MODE' button for 2 seconds
- The vehicle screen will now display 'SETTINGS'
- Press the 'Track -' button until the display shows 'FADER ADJUST'
- Press the 'MODE' button to select
- Adjust the fader with 'Track +' and 'Track -' buttons
- Press 'MODE' button to exit or wait for 10 seconds

To Adjust Clock

- Press and hold 'MODE' button for 2 seconds
- The vehicle screen will now display 'SETTINGS'
- Press 'MODE' button to select. The screen will now display 'INFO/CLOCK'
- Press and hold 'Track -' to enter time adjust mode
- Press 'Track +' to adjust the time digit
- Press 'Track -' to move onto the next time digit
- Press 'MODE' button to exit or wait for 10 seconds

To Adjust Trip Computer

- Press and hold 'MODE' button for 2 seconds
- The vehicle screen will now display 'SETTINGS'
- Press 'MODE' button to select. The screen will now display 'INFO/CLOCK'
- Press 'Track +' to access trip information
- Press 'Track +' repeatedly to scroll through trip information options
- Press 'Track -' to return to clock display
- Press 'MODE' button to exit or wait for 10 seconds

Config. 4 (4*)

To Adjust Clock

- Press and hold 'ENTER' button for 8 seconds
- Use 'Track -' to adjust hours
- Use 'Track +' to adjust minutes
- Press 'ENTER' button to set the time or press and hold 'ENTER' button to exit the menu without saving changes

Config. 5 (5*)

To Enter Menu

Hold 'Hang Up'

To Change Minutes

Press 'Track +'

To Change Minutes

Press 'Track -'

Config. 6 (6*)

To Adjust Clock

- Press and hold 'Source' button on the steering wheel until the time displayed on the dashboard flashes '00:00' for 1 second. This signifies that clock setting mode has been entered.
- Use 'Volume +' to adjust hours and 'Volume -' to adjust minutes
- Once the correct time has been set, wait for 5 seconds and the display will flash 00:00 for 1 second to signify that clock setting mode has been exited.

Config. 7 (7*)

To Access System Settings

- Press and hold 'Source' button for 2 seconds
- Use 'Volume +' and 'Volume -' to scroll through settings (ie. Lang, IGN Logic, Clock Sync)
- Press 'Track +' and 'Track -' to change settings
- Press 'Source' to exit

d. Diagram Chart

Important: Please note, connectors are shown from the terminal side and not the wire side

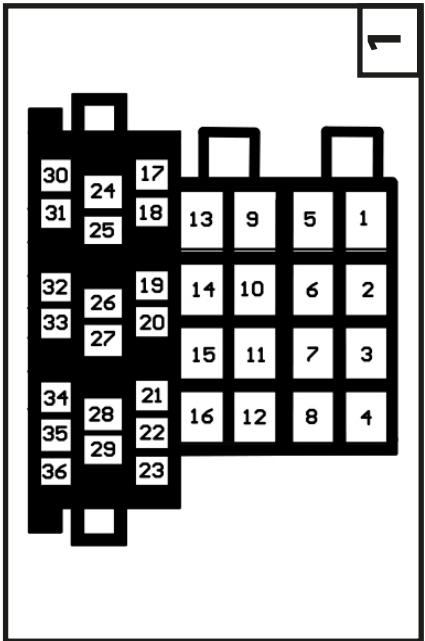

1

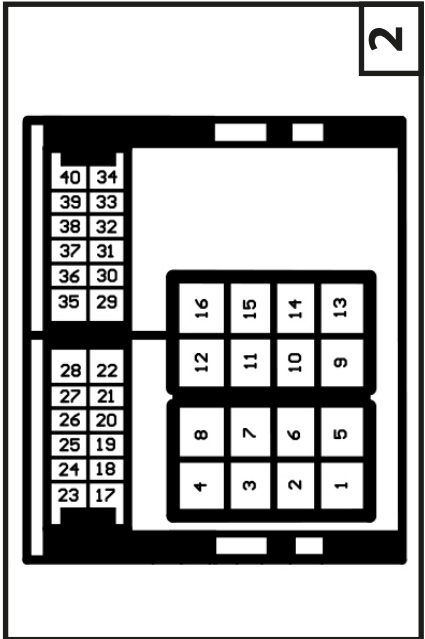

2

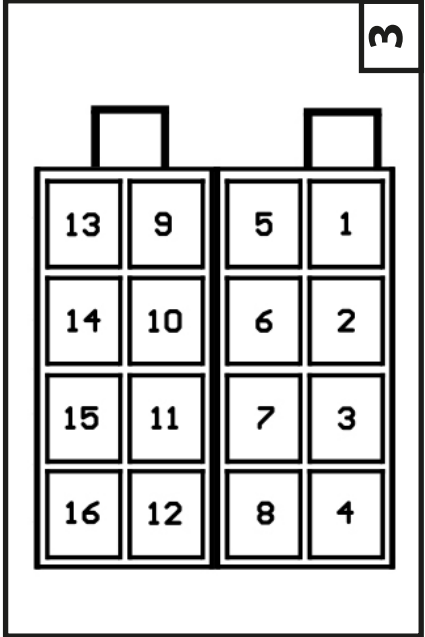

3

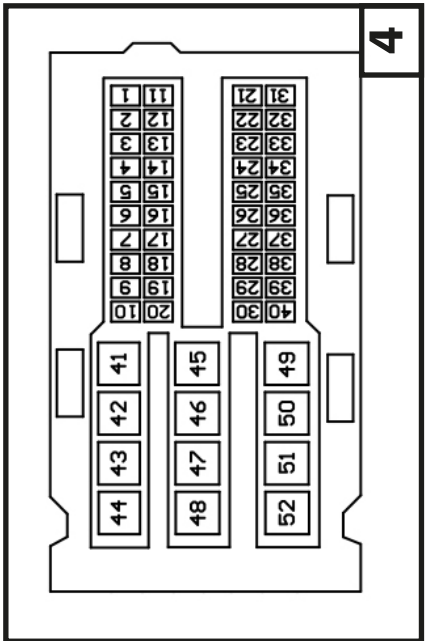

4

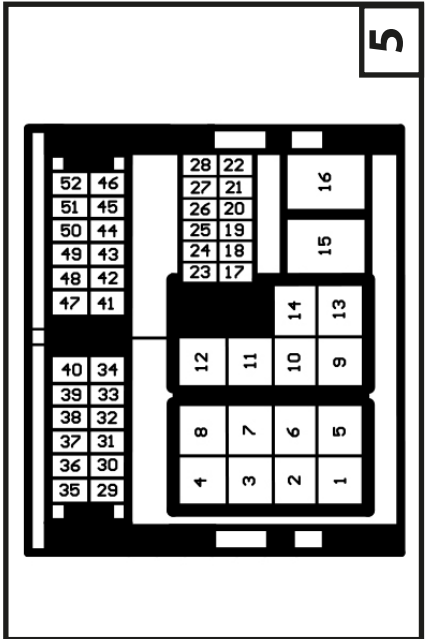

5

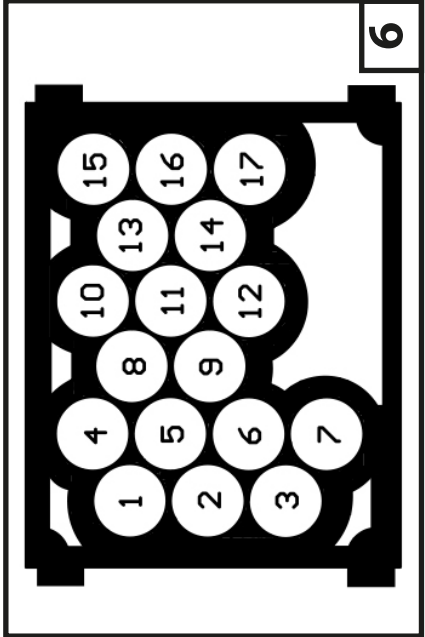

6

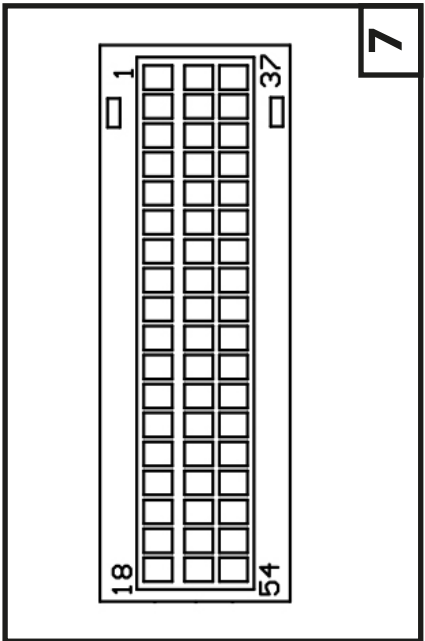

7

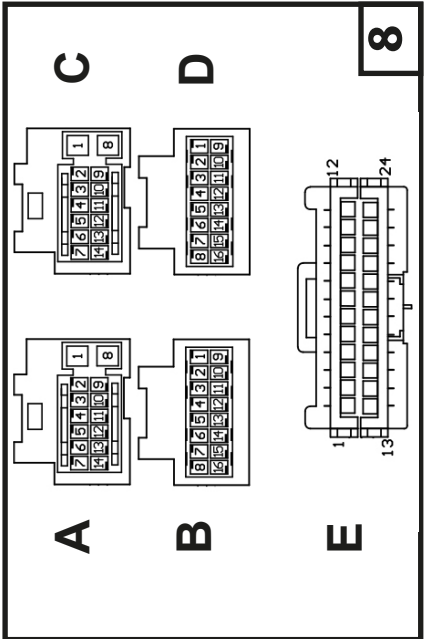

8

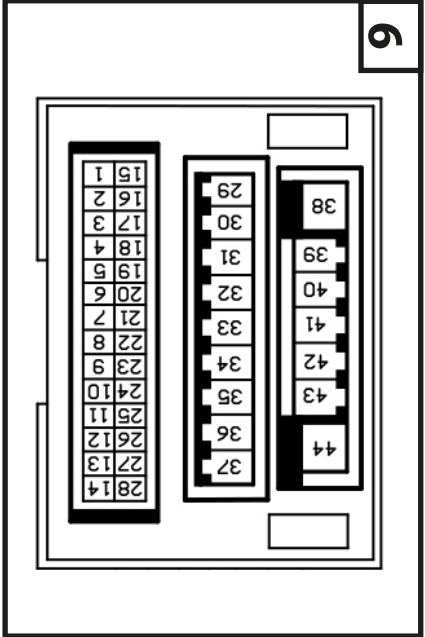

9

Important: Please note, connectors are shown from the terminal side and not the wire side

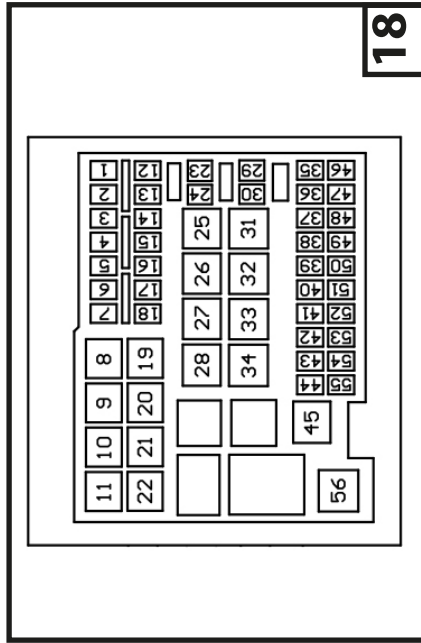
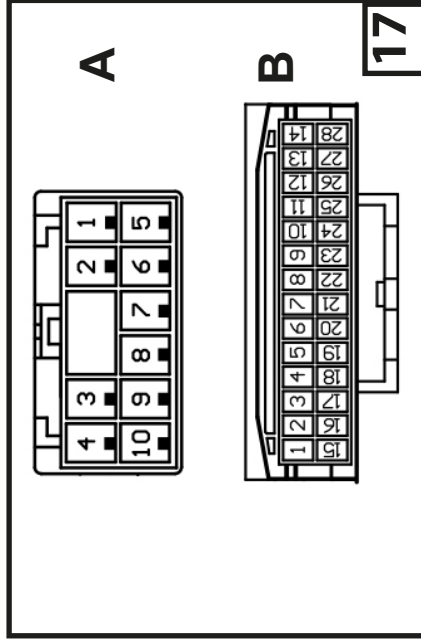
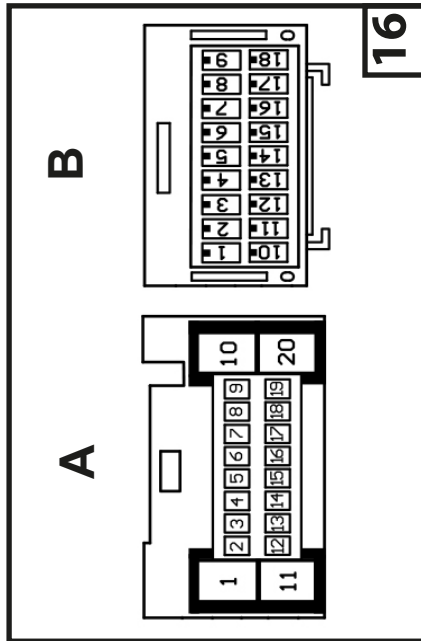
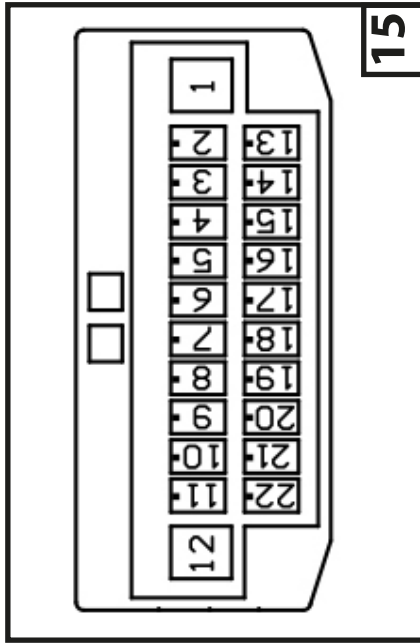
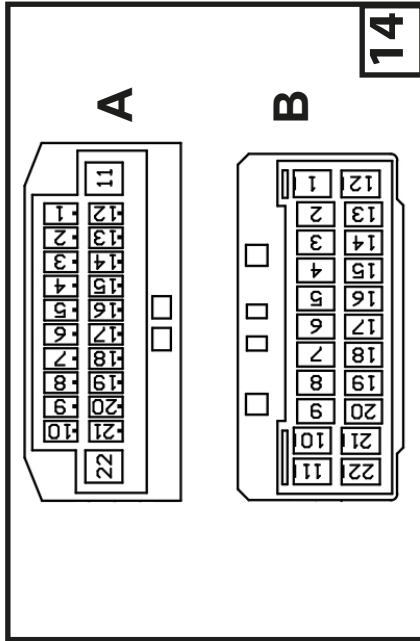
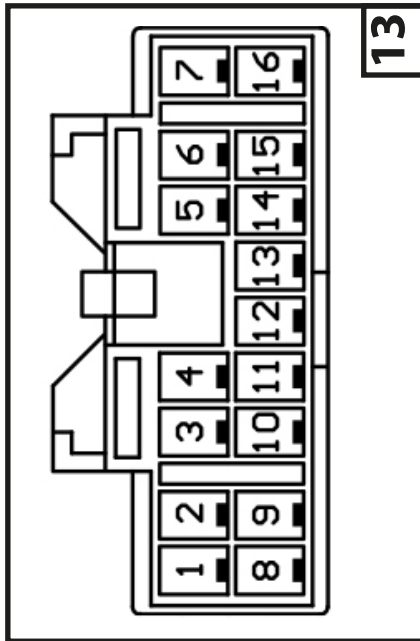
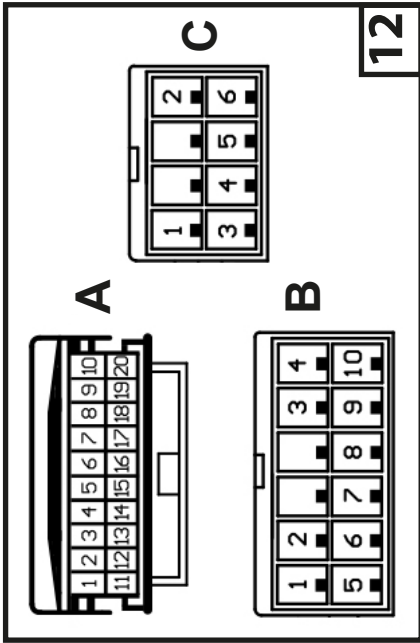
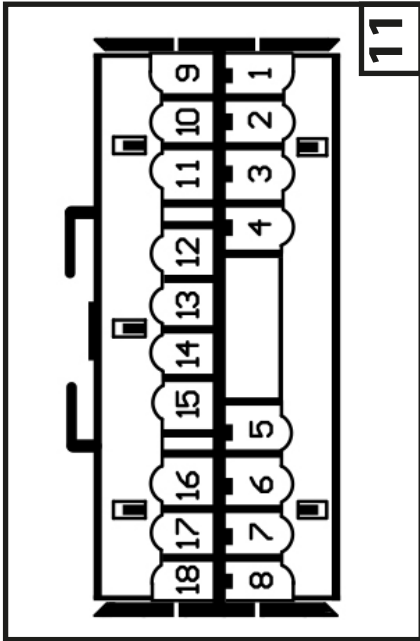
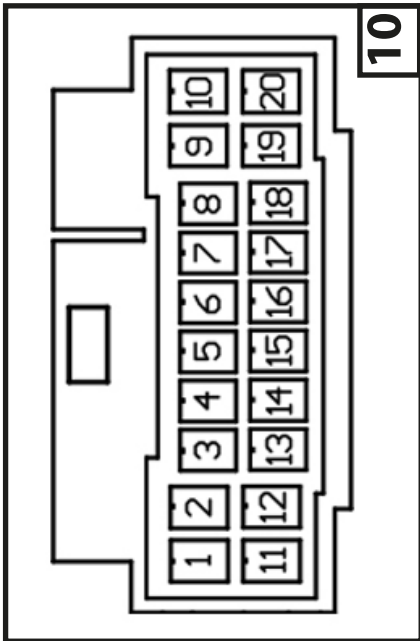

Important: Please note, connectors are shown from the terminal side and not the wire side

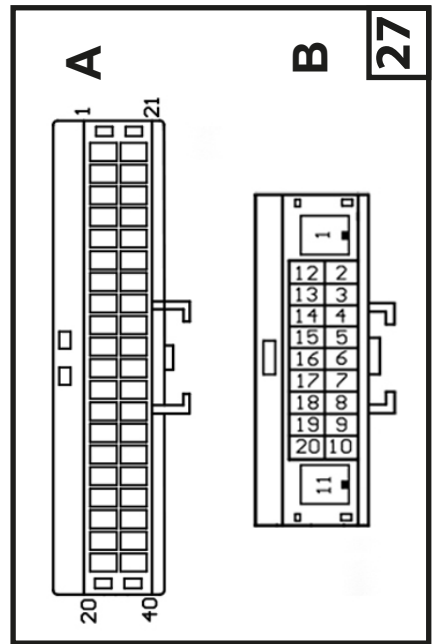
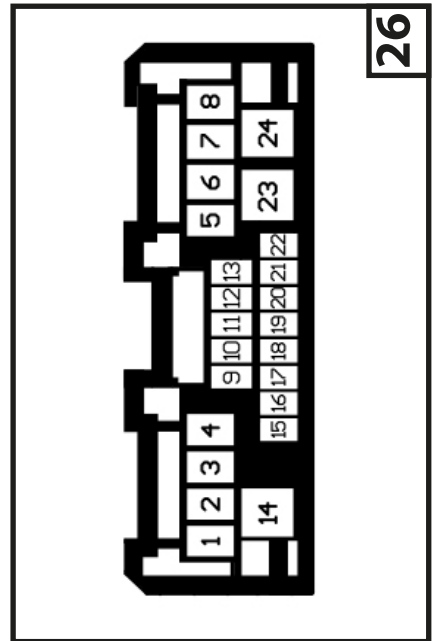
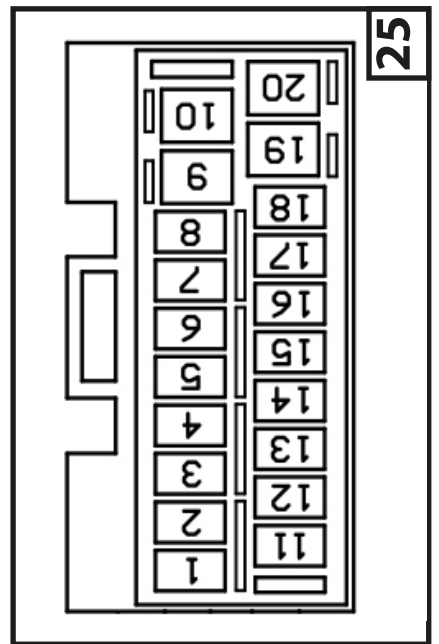
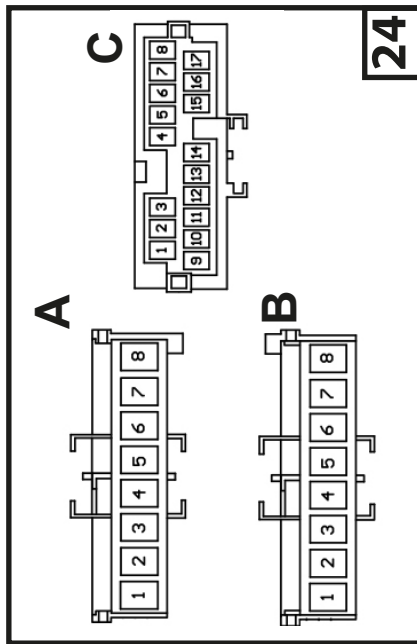
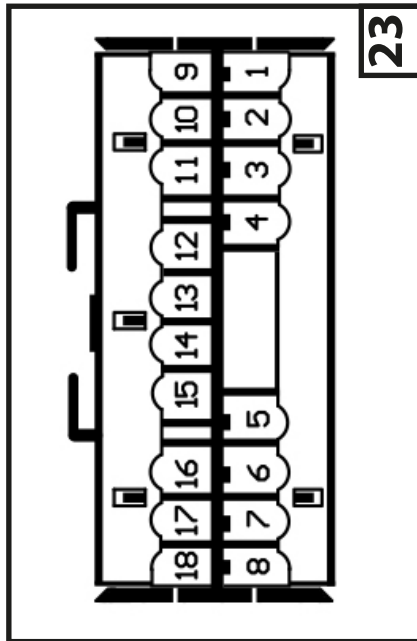
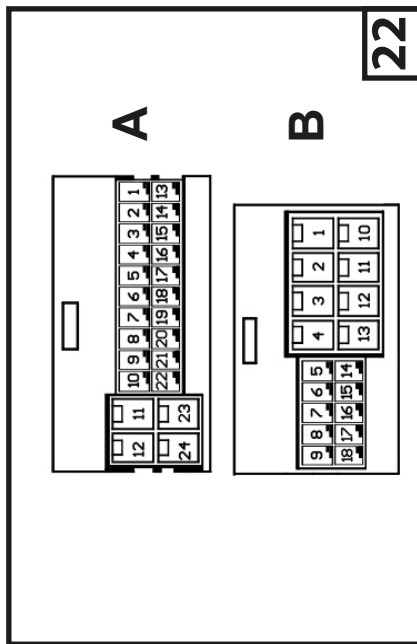
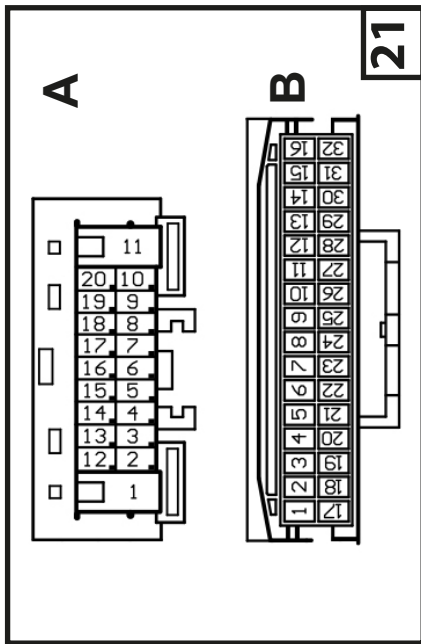
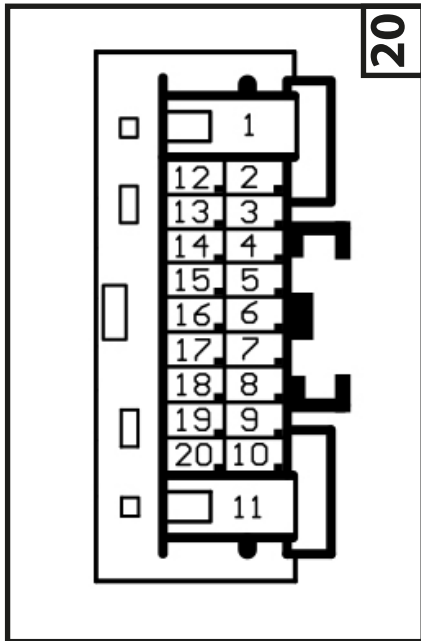
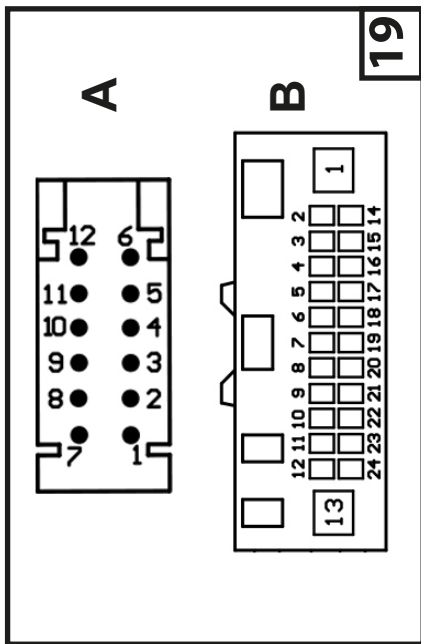

Important: Please note, connectors are shown from the terminal side and not the wire side

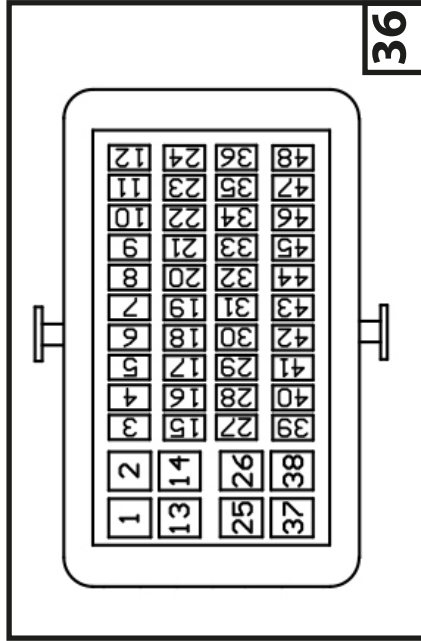
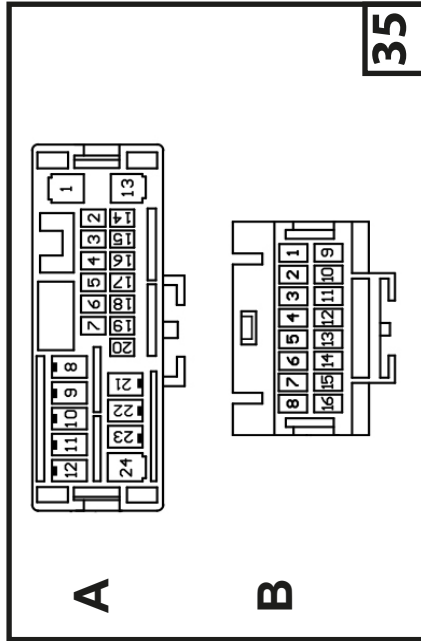
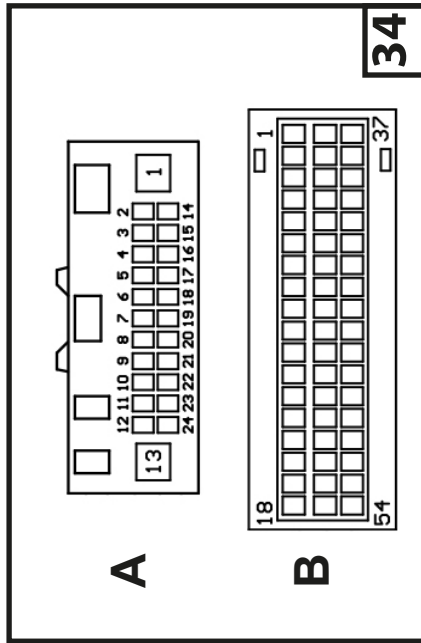
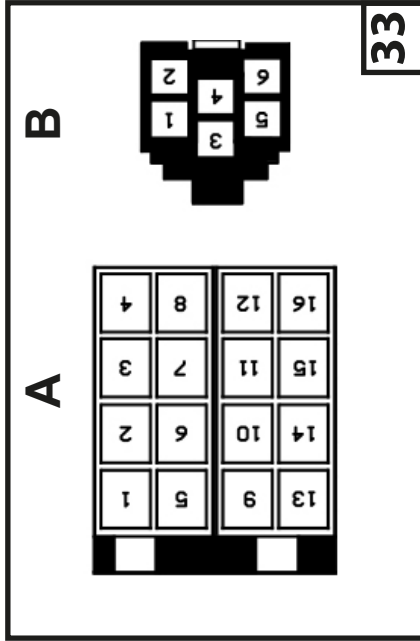
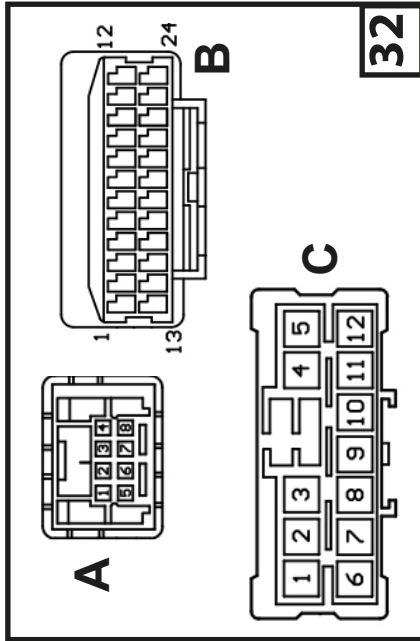
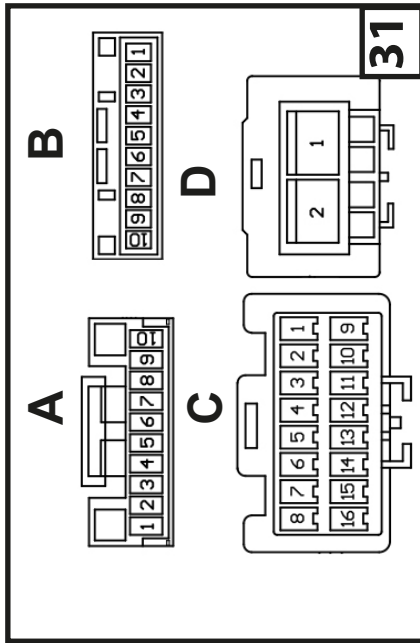
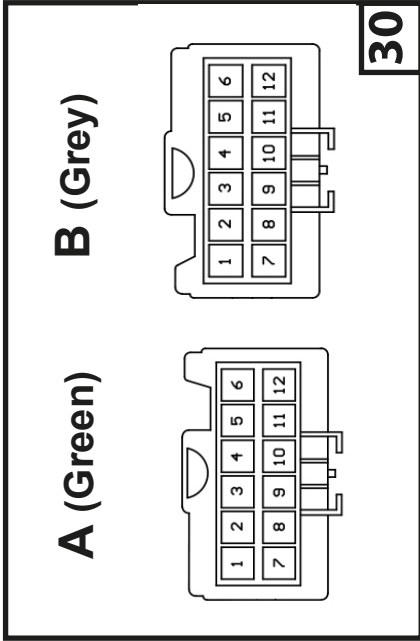
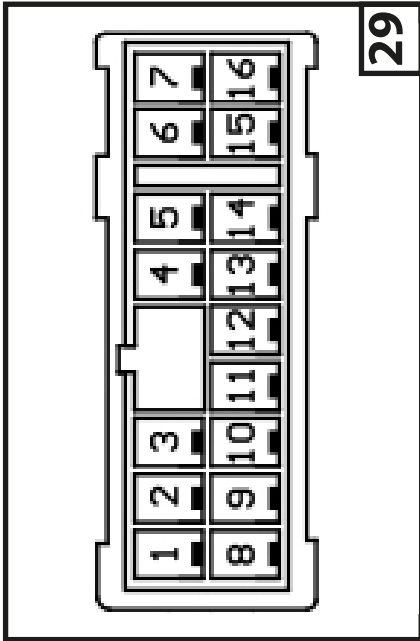
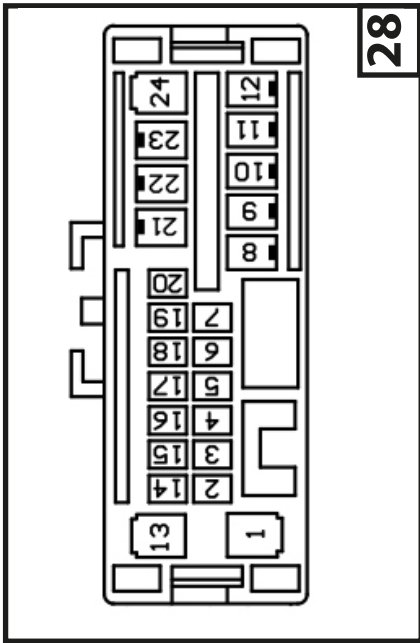

Important: Please note, connectors are shown from the terminal side and not the wire side

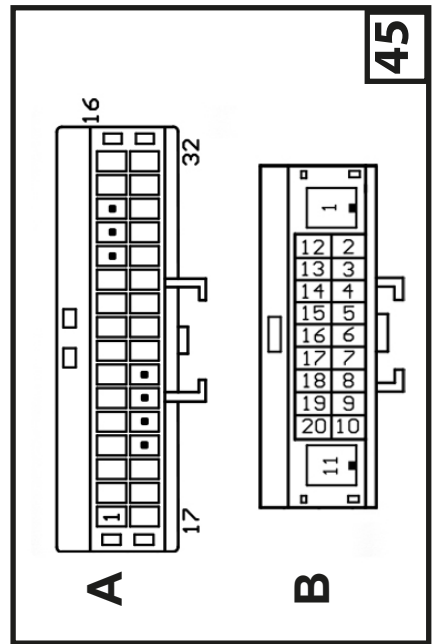
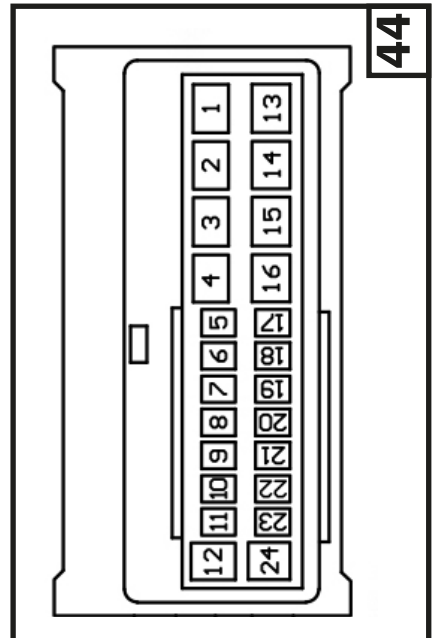
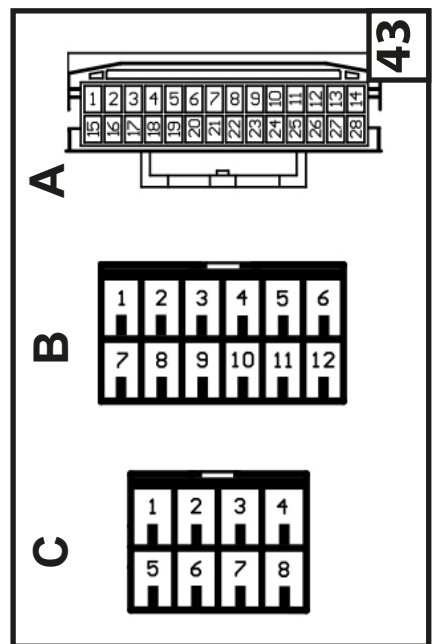
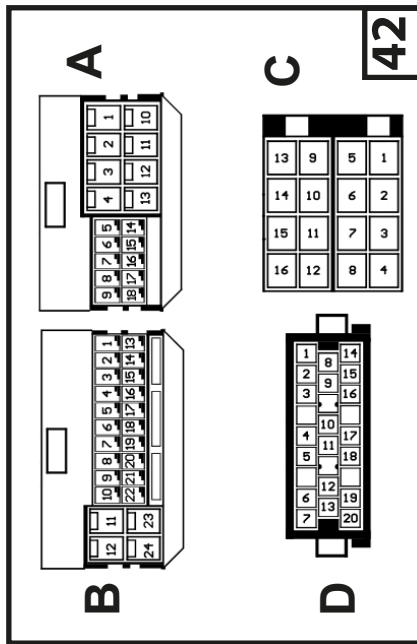
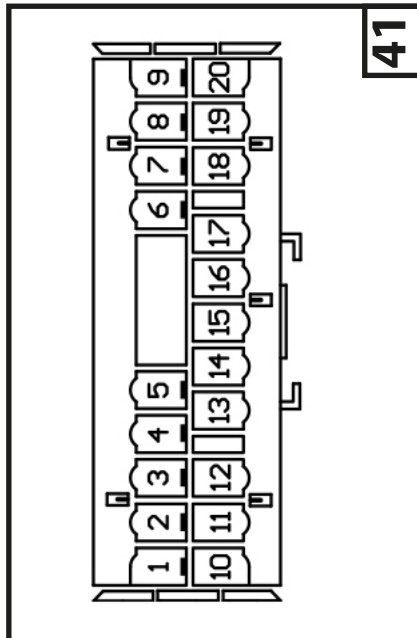
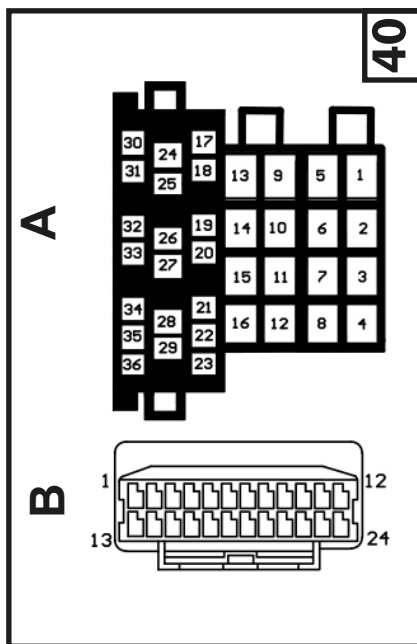
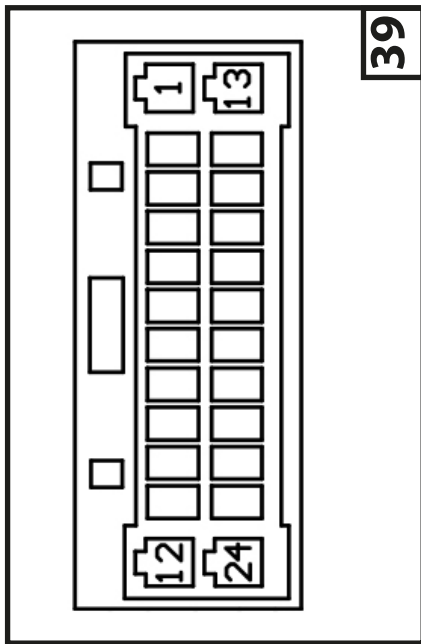
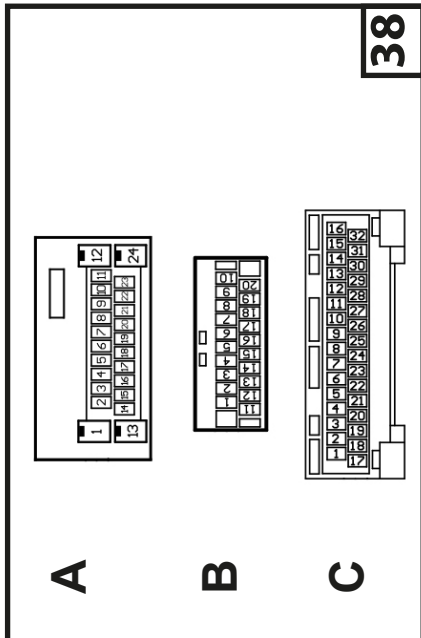
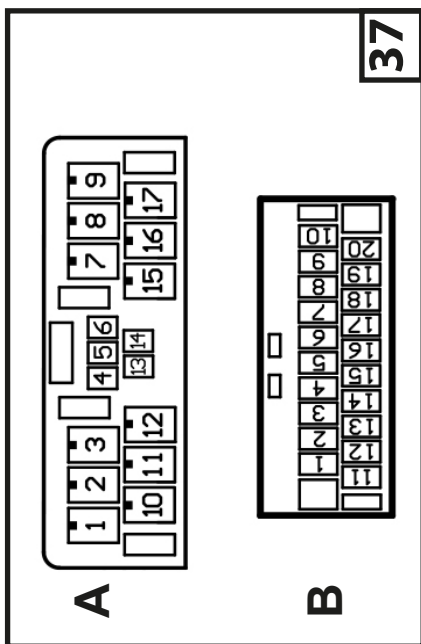

Important: Please note, connectors are shown from the terminal side and not the wire side

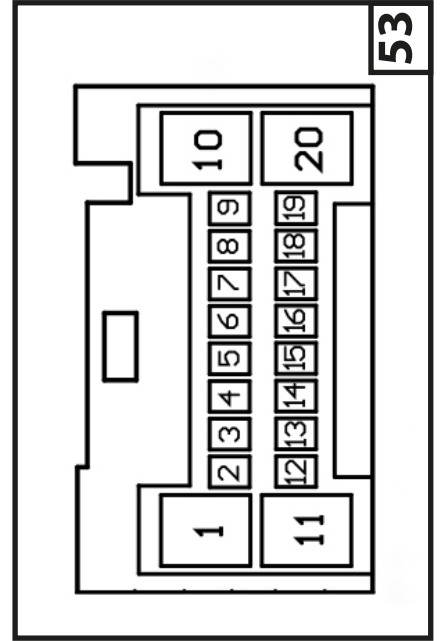
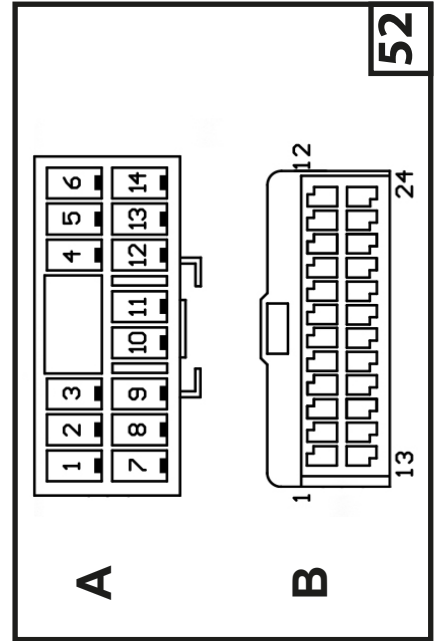
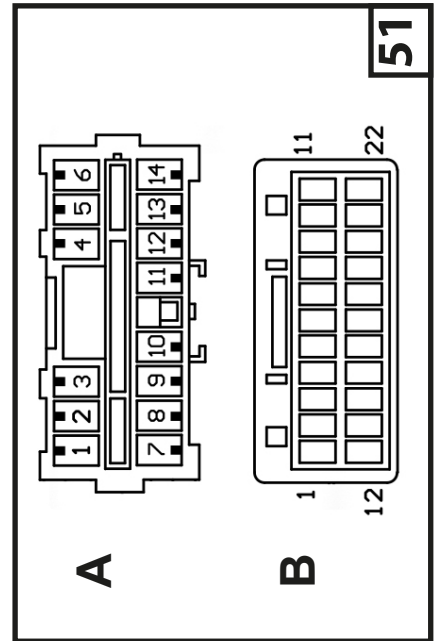
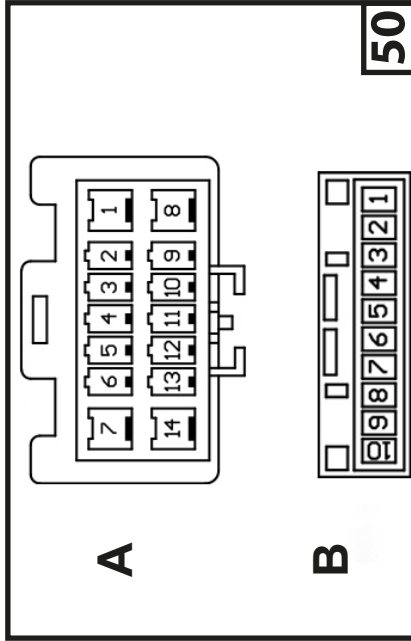
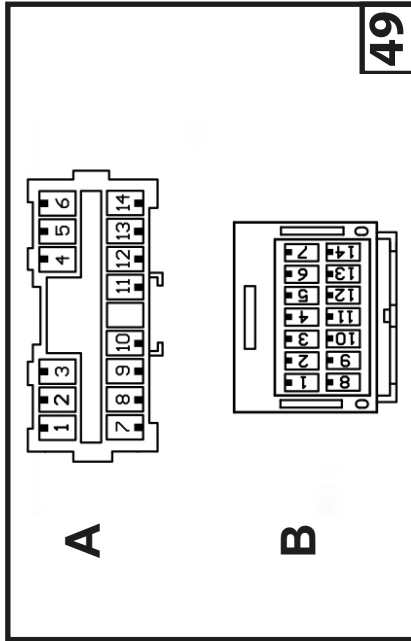
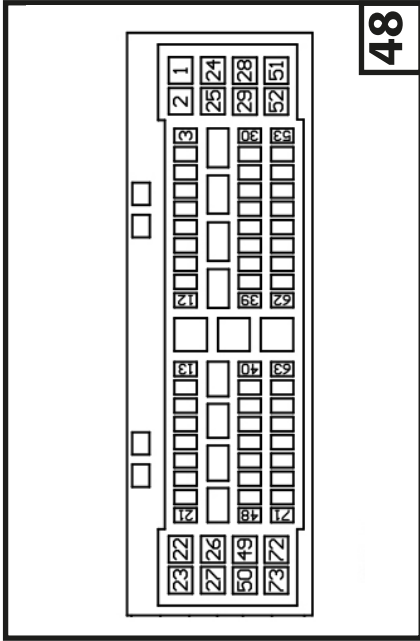
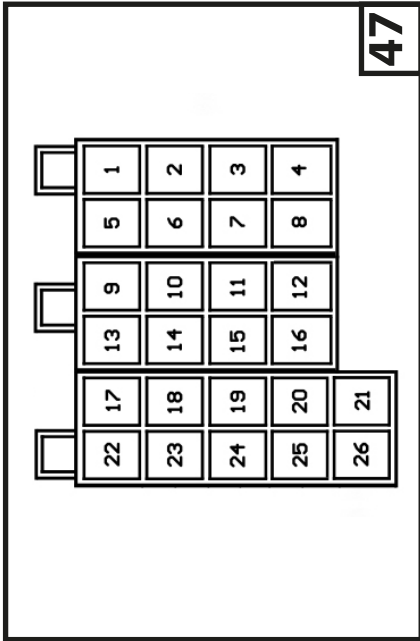
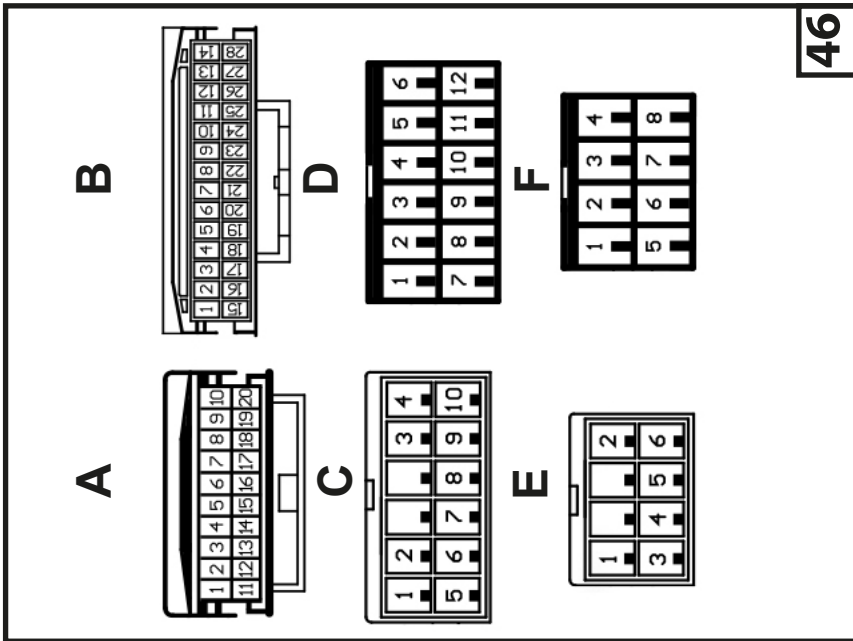

Important: Please note, connectors are shown from the terminal side and not the wire side

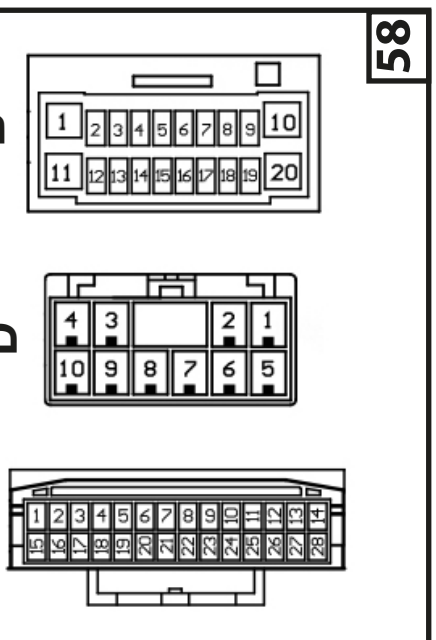
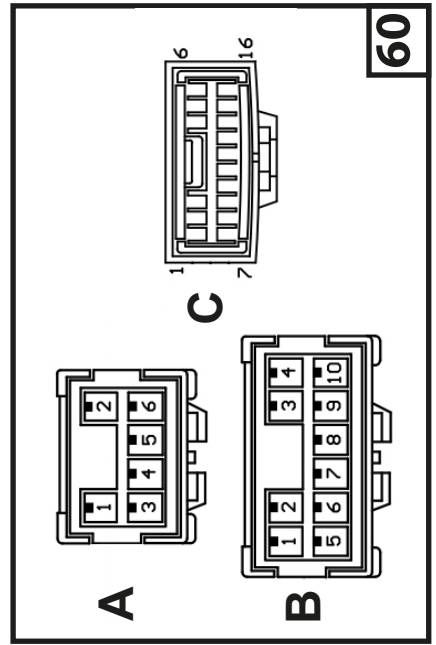
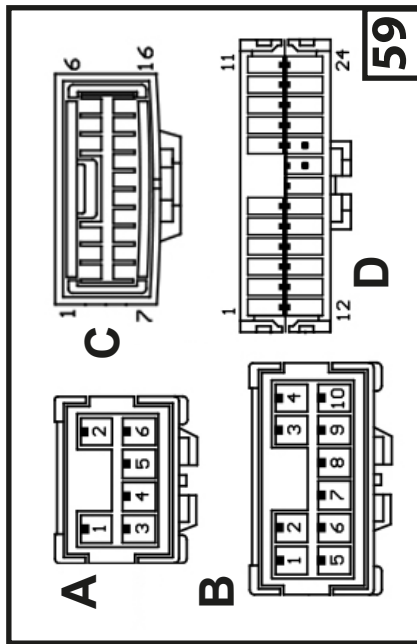
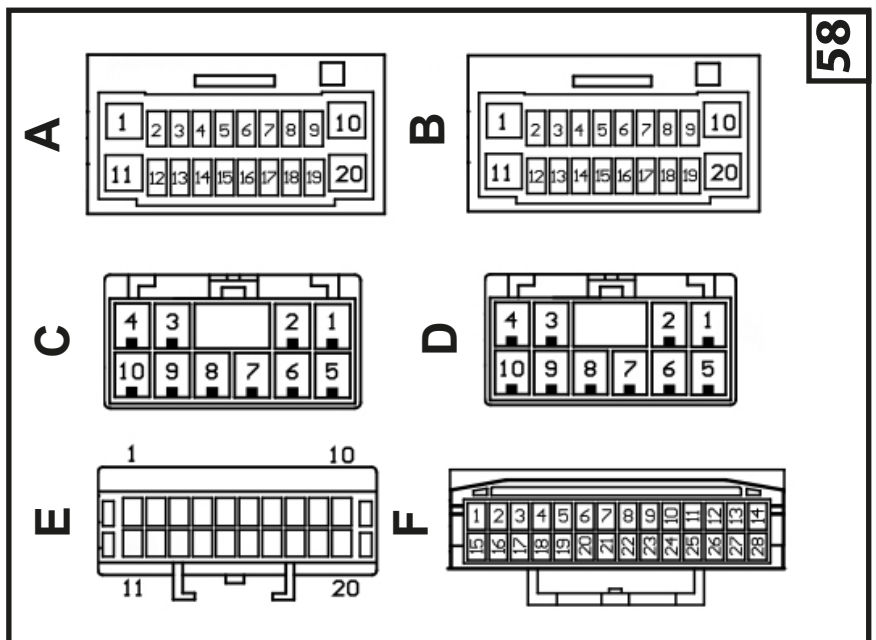
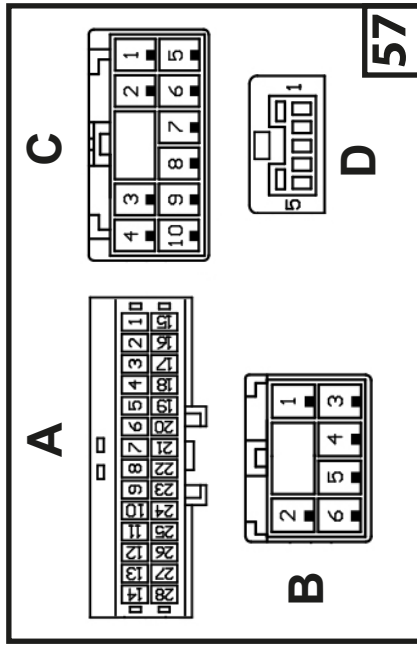
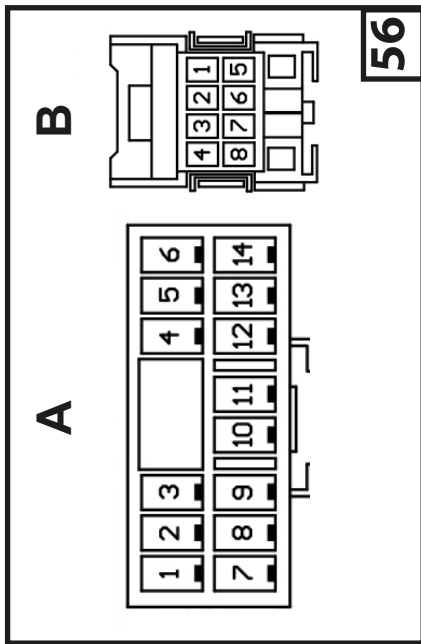
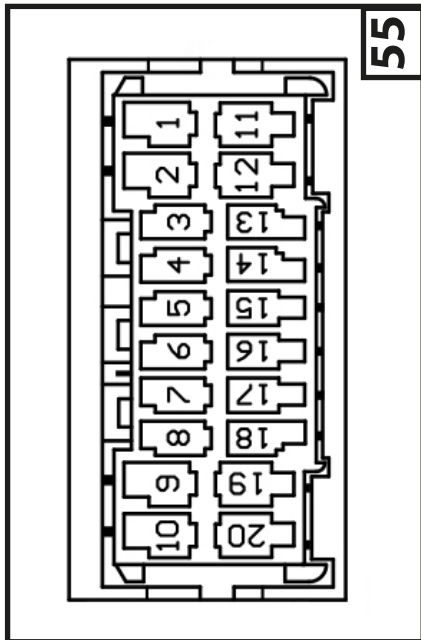
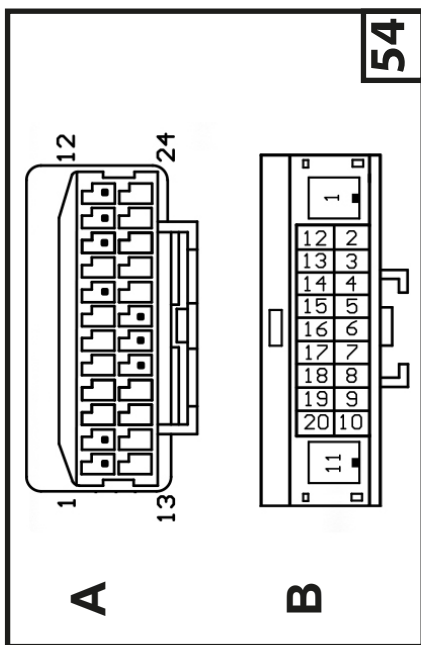

Important: Please note, connectors are shown from the terminal side and not the wire side

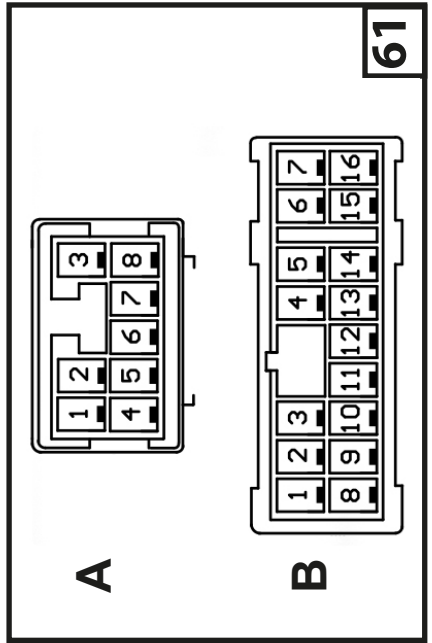
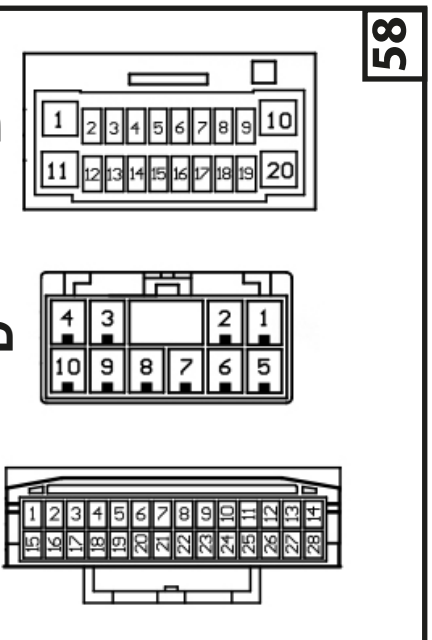
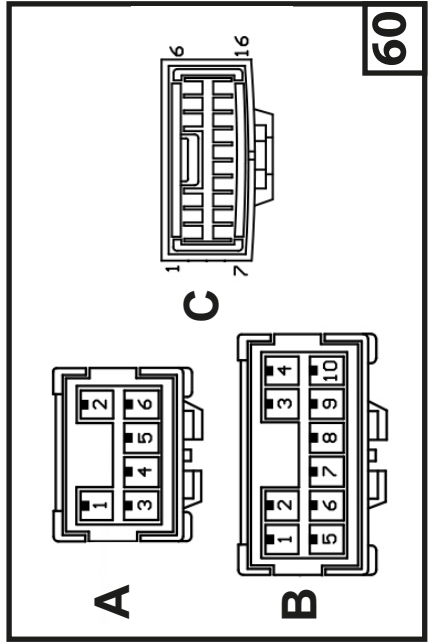
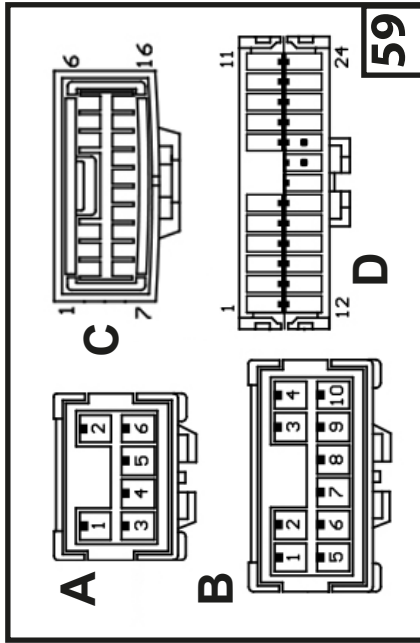
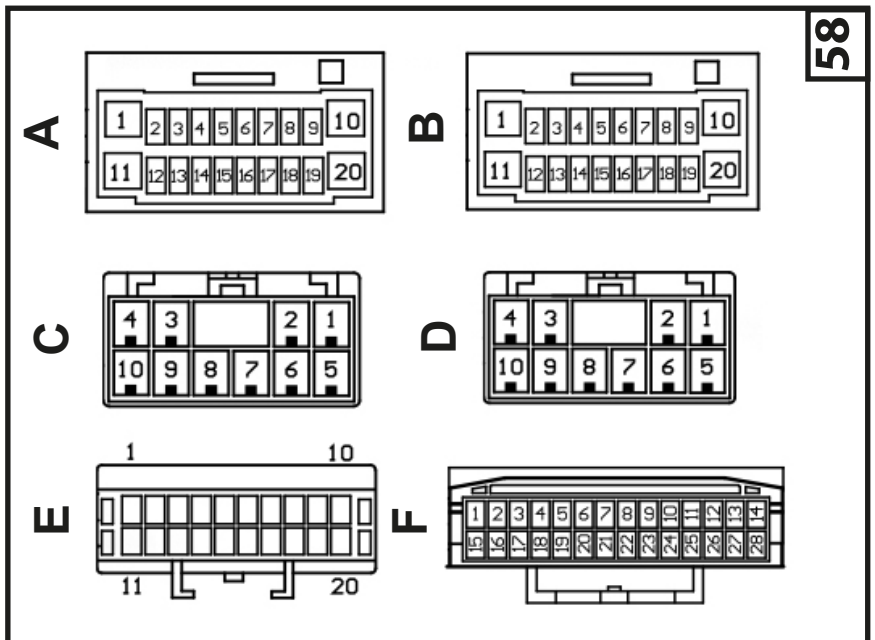
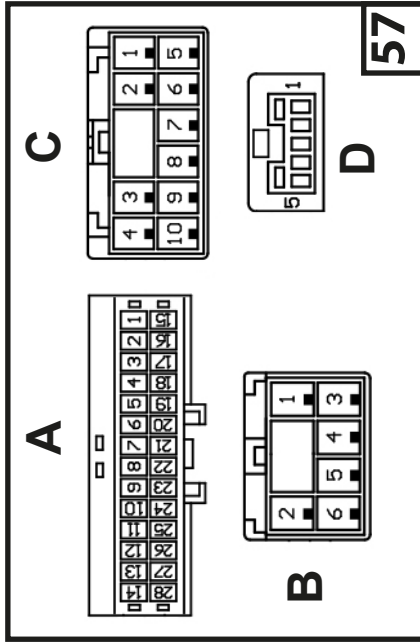
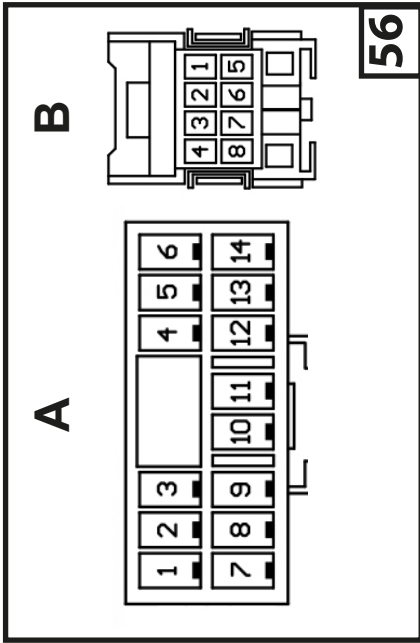
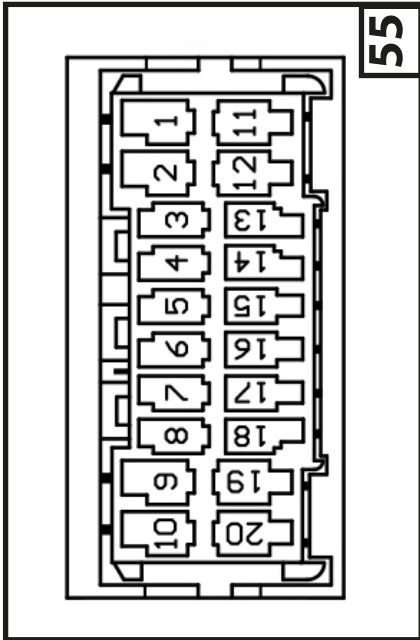
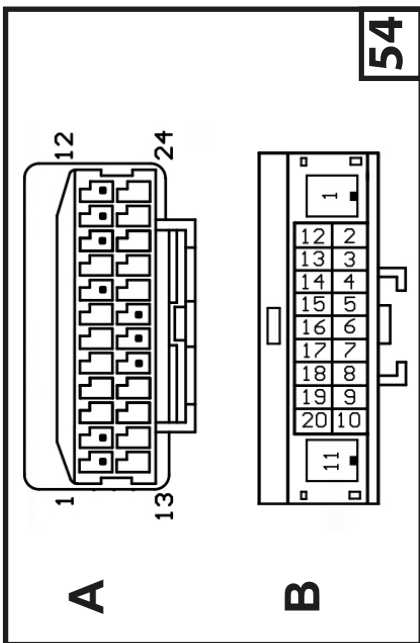

NOTES
